



C800

Core™2 Duo Dual-Core 3U cPCI SBC



- Rugged 3U cPCI Single-Slot SBC
- System Controller or Peripheral Board Operation
- Intel® L7500 Core™2 Duo (Merom) processor @ 1.67 GHz
- On-chip 32 kB Data/32 kB Instruction L1 Caches
- On-chip 4 MB L2 Cache
- Up to 2 GB DDR2 SDRAM
- Up to 8 GB FlashDisk
- On-board High Performance Graphics Controller (RGBHV, DVI, RS-170)
- Two Gigabit Ethernet Ports
- Two RS-232/422/485 Serial Ports
- Eight Discrete I/O Lines
- One SATA II Interface
- Two USB 2.0 Interfaces
- High Definition Audio Output
- Two Temperature Sensors
- Real Time Clock with Capacitor Backup
- Avionics Windowed Watchdog Timer
- One PMC Compliant Slot
- RTOS Support
 - Windows XP™ & Vista™
 - WindRiver VxWorks®
 - Linux
 - INTEGRITY
- Conduction and Air Cooled Versions
- Vibration and Shock Resistant

Aitech Defense Systems, Inc.

A member of the Ai-Rugged Group

9301 Oakdale Ave, Chatsworth, CA 91311

Tel: (888) Aitech-8 (248-3248) Fax: (818) 718-9787 e-mail: sales@rugged.com web: www.rugged.com



C800 - Unmatched Performance with Windows Desktop Convenience

Aitech's C800 is a ground breaking Windows compatible rugged cPCI SBC, based on Intel's new highly integrated, high performance Santa Rosa platform.

Powered by Intel's next generation Santa Rosa platform, comprising the L7500 Core2 Duo (Merom) dual-core processor with its large integrated on-chip L1 and L2 cache, the GM965 Express Chipset, and ICH8M Controller Hub, the C800 provides the highest performance available in a 3U cPCI SBC for harsh environment applications.

To ensure high reliability under extreme operating conditions the C800 is capable of accurate temperature self-monitoring and power dissipation control through on-board temperature sensors.

The C800 implements large on-board memory arrays to support the processor and user application needs. Memory resources include up to 2 GB fast DDR2 (Double Data Rate) SDRAM and up to 8 GB Flash Disk (NAND Flash) for user/application specific parameter storage.

An on-board graphics controller provides video and 2D/3D graphics processing and output support for various displays.

In addition to its high performance processor architecture, the C800 provides a wide variety of I/O, including two Gigabit Ethernet ports, two high-speed serial communications ports, two USB 2.0 ports, one SATA II interface, up to eight general-purpose discrete I/O channels, and a high definition audio stereo output. To further expand its capabilities, the C800 is equipped with an industry standard PMC slot allowing for installation of additional modules and functionality.

The C800 may perform as either the CompactPCI system controller or as a peripheral board. When configured as system controller, the C800 can support up to six additional cards on the CompactPCI backplane, providing clock, arbitration and interrupt capabilities.

The highly integrated design of the C800 guarantees unmatched performance and versatility for a rugged conduction or air-cooled 3U cPCI SBC.

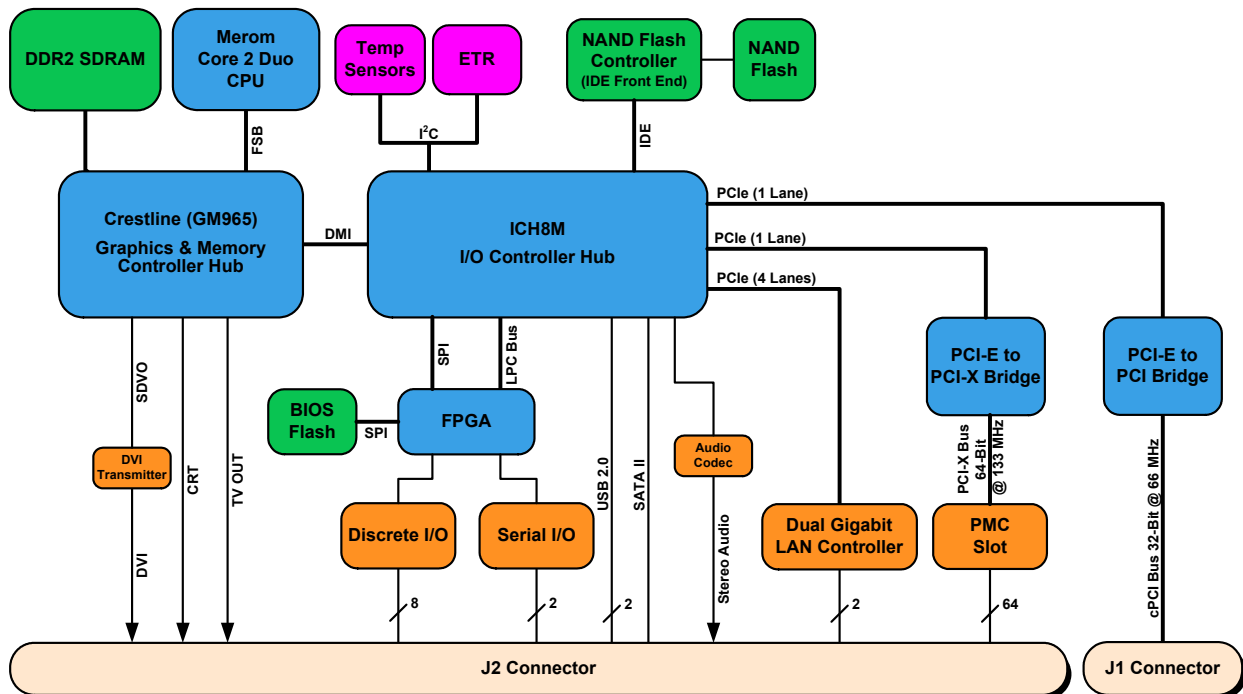



Functional Description

Processor and Bus Architecture

The C800 is a powerful processing platform achieved using Intel's new Core2 Duo dual-core processor, the GM965 Express Chipset, the ICH8M I/O Controller Hub, and extensive supporting memory arrays. In addition the board's architecture was designed to utilize all bus interfaces to the maximum.

Processor

The Core2 Duo dual-core processor is Intel's next generation, high performance, low power processor based on the Intel Core micro-architecture. Dual processing cores, combined with 32 kB on-die instruction and data L1 caches, and a 4 MB L2 cache, provide enhanced performance, while a 667 MHz Front Side Bus (FSB) ensures high speed memory and I/O access.

The processor, operating at 1.67 GHz (with potentially higher frequency versions available in the future), implements Intel's Virtualization Technology, enabling the creation of multiple virtual partitions, each running a different application.

The Core2 Duo provides advanced power management features including Enhanced Intel SpeedStep[®] Technology and dynamic FSB frequency switching.

System Architecture

Supporting the Core2 Duo's high performance and to provide a fast data highway for high throughput transfers, the C800 implements Intel's next generation 965 Express Chipset Family Graphics Memory Controller Hub (GMCH) and I/O Controller Hub (ICH8M). A Direct Media Interface (DMI) bus provides efficient high-bandwidth communication between the GMCH and ICH8M.

The GMCH provides the host interface controller, system memory interface (SDRAM), direct media interface, external graphics interface, and an integrated graphics engine. The ICH8M integrates a number I/O controllers and interfaces for legacy and high speed devices.

The ICH8M provides an LPC bus as well as multiple high speed PCIe lanes used to implement cPCI and PCI-X busses via appropriate bridge devices.

Memory

The C800 is equipped with large memory arrays providing the user with extensive volatile and non-volatile memory resources. These arrays include up to 2 GB fast DDR2 (Double Data Rate) SDRAM operating at 667 MHz, up to 2 MB of Flash BIOS, and up to 8 GB Flash File (NAND Flash) for mass storage oriented applications.

CompactPCI

The C800 utilizes one of the ICH8M PCIe lanes and a PCIe to PCI bridge to implement a standard 32-bit/66 MHz PCI interface, in accordance with the PCI specification.

In a CompactPCI subsystem, the C800 is capable of performing either as a system controller, or as a peripheral card. As system controller, the C800 supports up to six additional cards on the PCI backplane providing them with clock signals and arbitration support.

The C800 PCI interface is universal, supporting both 3.3 V and 5 V PCI signaling levels. It drives 3.3 V signals and is 5 V tolerant.

Integrated Graphics Controller

The C800 includes an on-board graphics controller implemented in the GM965 Express Chipset. The graphics controller is capable of 2D and 3D graphics processing, supporting Microsoft DirectX 10 and SGI OpenGL 1.5/2.0.

The graphics controller also includes a video engine providing hardware motion compensation, 4-channel MPEG YUV, and numerous additional features.

The C800 provides outputs for DVI, RGB, and composite video monitors.

I/O Interfaces

In addition to its superior processing power, the C800 provides many I/O capabilities (relative to its small form factor).

Ethernet

Two 10BaseT, 100BaseTX and 1000BaseT interfaces are implemented in a Dual Gigabit LAN Controller (with integrated physical layer) using four of the ICH8M PCIe lanes.

Serial I/O

The C800 provides two serial ports supporting RS-232/422/485 physical interfaces.

USB 2.0 Ports

The C800 includes a USB Rev. 2.0 host controller (backward compliant with Rev. 1.0 and Rev. 1.1), integrated in the ICH8M device, providing USB 2.0 ports. The controller integrates the USB transceivers supporting high-speed, full-speed, and low-speed signaling. The C800 is capable of providing power to downstream devices.

Discrete I/O

Up to eight single-ended or four differential general-purpose discrete I/O channels are provided on the C800. Each channel may be independently configured as input or output. Configured as input each of these



channels may be programmed to generate an interrupt on any level shift event.

The eight discrete I/O signals are divided into four groups, each controlling two signals. Each group may be configured as two single-ended TTL channels or one differential RS-422 channels.

SATA II

One SATA II interface is provided, to enable connection of an external mass storage device to the C800. The SATA II interface is fully compliant with the Serial ATA 1.0 specification, supporting data transfer rates of up to 300 MB/s.

HD AUDIO

The ICH8 Controller Hub supports Intel's High Definition (HD) Audio, which is compliant with Microsoft's Universal Audio Architecture (UAA). Using an HD Audio codec, the C800 provides a stereo interface through its cPCI Connector.

PMC Expansion

The C800 provides one IEEE 1386-2001 or ANSI/VITA 20-2001 compliant PMC expansion slot for extended flexibility and integration of additional I/O to the board.

The PMC slot resides on a fast 64-bit PCI-X bus port provided by the ICH8M, via a PCIe to PCI-X bridge, and is capable of up to 133 MHz bus operation.

The universal PCI interface supports both 3.3 V and 5 V PCI signaling levels.

I/O Routing

All I/O interface signals are available at the C800 J2 CompactPCI rear panel connectors. PMC I/O may also be routed to the J2 connector at the expense of on-board I/O connectivity.

The C800 is available in a number of basic I/O variants providing several combinations of on-board and PMC I/O at the J2 connector. Refer to the C800 ordering information for additional detail.

Timers

The C800 includes one 32/64-bit and two 32-bit timers/counters providing high-resolution timing functionality as well as chaining for long interval counting applications.

A Real-Time Clock (RTC) provides time and date keeping. The RTC is backed up by a large capacitor for long-term parameter storage.

A watchdog timer is also available on the C800. Implemented in the system FPGA, the watchdog is an avionics style programmable windowed watchdog timer, which must be serviced within a software programmable window defined by minimum and maximum times. If serviced too early, too late, or not

at all, this watchdog timer will generate a timeout event. It may be independently set to generate a non-maskable interrupt or reset the SBC.

Software

Test and Diagnostic Features

The C800 is supplied with an extensive firmware package, including startup firmware (boot software), AIMon monitor/debugger tool, AIDiag diagnostic tool, and BIT. BIT may be executed during power-up or at any time after the board has been booted.

A JTAG/COP interface to the processor is provided for debugging and development purposes.

Operating Systems

The C800 is available with complete Board Support Packages (BSP) for Microsoft Windows XP, Microsoft Windows Vista, WindRiver VxWorks, Green Hills INTEGRITY, and Linux.

BSPs include drivers for all on-board resources, allowing the user to take full advantage of the C800 powerful features.

Mechanical Features

The C800 is available in both air-cooled and conduction-cooled mechanical formats. Both are single slot 3U modules.

A custom metal frame integral to the conduction-cooled version of the C800 provides excellent rigidity and shock resistance. The frame also provides an array of stiffeners to support rugged PMC boards.

Dimensions and Form Factor

- Air-cooled: per PICMG 2.0 R3.0
- Conduction cooled: per ANSI/VITA 30-1991

Weight

- Air-cooled: < 300 g (0.66 lbs)
- Conduction cooled: < 330 g (0.73 lbs)

Thermal Management

Careful mechanical design, including custom heatsink modules combined with a metal frame, allow for optimal heat dissipation and relief of the board. The C800 is also equipped with two temperature sensors, located at temperature-critical locations, to monitor board temperature and provide temperature data to user application software.

