

F14 - 3U CompactPCI®/Express Pentium® M SBC

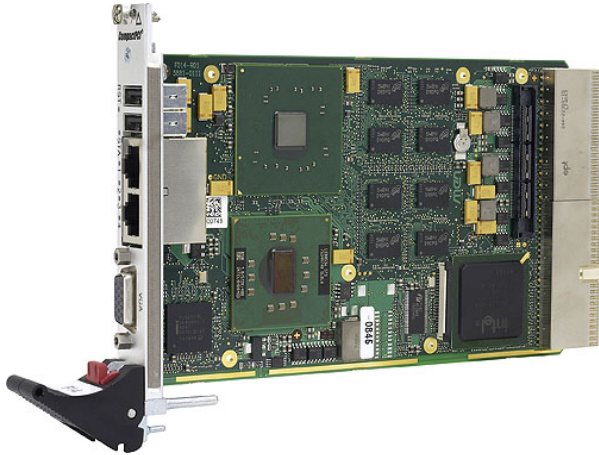

- **ULV Celeron® M 373, 1 GHz up to Pentium® M 760, 2 GHz**
- **PCI Express® four x1 links**
- **4 HP system master or stand-alone**
- **32-bit CompactPCI® or cPCIe up to 2 GB DDR2 DRAM soldered**
- **CompactFlash® slot**
- **2 SATA interfaces Video via VGA and 2 SDVO2 Gigabit Ethernet (PCIe) up to 8 USB 2.0**
- **High Definition audio**
- **Board controller**
- **-40 to +85°C screened versions**

Equipped with the high-performance Intel® 2-GHz Pentium® M down to the 1-GHz ultra low voltage Celeron® M processor, the single-board computer F14 is a versatile 4 HP / 3U (single-slot, single-size Eurocard) CompactPCI® board, designed especially for embedded systems which require high computing and graphics performance and low power consumption. All board versions come with tailored passive heat sinks within 4 HP height. Depending on the processor version forced air cooling is required inside the CompactPCI® system.

The F14 is suited for a wide range of industrial applications, for example for monitoring, vision and control systems as well as test and measurement. Main target markets comprise industrial automation, multimedia, transportation (railways, commercial vehicles), aerospace, shipbuilding, medical engineering and robotics. The robust design of the F14 together with the low-power Pentium® M processors make the board especially suited for use in rugged environments in mobile applications with regard to temperature, shock, vibration, humidity or dust according to the applicable DIN, EN or IEC industry standards. The F14 is also ready for coating so that it can be used in humid and dusty environments. The F14 offers a 32-bit/33-MHz interface to the CompactPCI® bus and can alternatively also be used without a bus system. In combination with a specific side card it can also perform system-slot

functionality in a CompactPCI® Express system.

Four PCI Express® links for high-speed communication requirements (such as Gigabit Ethernet, graphics) are supported on the board.

The DDR2 DRAM is soldered to F14 to guarantee optimum shock and vibration resistance. An IDE-driven robust CompactFlash® device offers nearly unlimited space for user applications. Apart from parallel ATA support, two serial ATA lines are also available.

The standard I/O available at the front panel of F14 includes graphics on VGA connector, two PCIe-driven Gigabit Ethernet interfaces (alternatively 1 Gigabit / 1 Fast Ethernet) as well as two USB 2.0 ports.

The F14 can be extended by a side card to 8 HP. I/O functions realized on the side card include two digital video outputs for flat panel connection via DVI, another four USB 2.0 ports and HD Audio. The F14 is also prepared for rear I/O where for example another two USB 2.0 ports can be connected.

Two watchdogs for thermal supervision of the processor and board temperature as well as for monitoring the operating system complete the functionality of the F14. The F14 operates in Windows® and Linux environments as well as under major real-time operating systems like VxWorks® or QNX®. The Award BIOS was especially designed for embedded system applications.

Equipped with Intel® components that come exclusively from the Intel® Embedded Line, the F14 has a guaranteed minimum standard availability of 5 years.

Technical Data

CPU

- ULV Celeron® M 373 up to Pentium® M 760
 - 1.0 to 2.0GHz processor core frequency
 - 400MHz or 533MHz front-side bus frequency
- Chipset
 - Northbridge: Intel® 915GM
 - Southbridge: Intel® ICH6M

Memory

- Up to 1MB L2 cache integrated in Celeron® M or 2MB L2 cache integrated in Pentium® M
- Up to 2GB SDRAM system memory
 - Soldered
 - DDR2
 - 400MHz or 533MHz memory bus frequency
 - Dual-channel, 2x64 bits
- 4Mbits boot Flash
- Serial EEPROM 2kbits for factory settings
- CompactFlash® card interface
 - Via on-board IDE
 - Type I
 - True IDE
 - DMA support

Mass Storage

- Parallel IDE (PATA)
 - One IDE port for local CompactFlash®
- Serial IDE (SATA)
 - Two channels via side-card connector, or: one channel via side card and one channel via rear I/O
 - Transfer rates up to 150MB/s

Graphics

- Integrated in 915GM chipset
 - Analog CRT DAC interface support
 - Supports max. DAC frequency up to 400 MHz
 - 24-bit RAMDAC support
 - Maximum resolutions: 2048 x 1536 pixels 16M colors @ 75Hz refresh rate (analog); 1600 x 1200 pixels 16M colors @ 60Hz (digital)
 - Incorporates PanelLink Digital technology (Silicon Image)
- VGA connector at front panel
- Two SDVO ports available via side-card connector
 - Two additional DVI connectors at front panel optional via side card
 - Simultaneous connection of two monitors

I/O

- USB
 - Two USB 2.0 ports via Series A connectors at front panel

- Four USB 2.0 ports via side-card connector
- Two USB 2.0 ports via rear I/O on request
- UHCI and EHCI implementation
- Data rates up to 480Mbits/s
- Ethernet
 - Two 10/100/1000Base-T Ethernet channels, or: one 10/100/1000Base-T and one 10/100Base-T channel
 - RJ45 connectors at front panel
 - Gigabit Ethernet connected by two x1 PCIe® links
 - On-board LEDs to signal activity status and connection speed
- High Definition (HD) audio
 - Accessible via side-card connector

Front Connections (Standard)

- VGA
- Two USB 2.0 (Series A)
- Two Ethernet (RJ45)

Miscellaneous

- Board controller
- Real-time clock, buffered by a GoldCap or alternatively a battery
- Watchdog timer
- Temperature measurement
- One user LED
- Reset button

PCI Express®

- Two x1 links to connect local 1000Base-T Ethernet controllers
- Two x1 links for extension through side-card connector, or:
- Three x1 links if one Gigabit Ethernet channel is replaced by Fast Ethernet
- Data rate 250MB/s in each direction (2.5 Gbits/s per lane)

CompactPCI® Bus

- Compliance with CompactPCI® Core Specification PICMG 2.0 R3.0
- CompactPCI® Express support (EXP.0 R1.0)
 - System slot
 - 32-bit/33-MHz CompactPCI® bus
 - V(I/O): +3.3V (+5V tolerant)

Busless Operation

- Board can be supplied with +5V only, all other voltages are generated on the board
- Backplane connectors used only for power supply

Technical Data

Electrical Specifications

- Supply voltage/power consumption:
 - +5V (-3%/+5%), approx. 2.5A (ULV Celeron® M 373), approx. 7.5A (Pentium® M 760)
 - +3.3V (-3%/+5%), approx. 1A
 - +12V (-10%/+10%), approx. 10mA
 - If the board is supplied with 5V only (typically without a bus connection), the 3.3V are generated on the board and fed to the backplane (3A max.)
- MTBF: 86,600h @ 40°C (derived from MIL-HDBK-217F)

Mechanical Specifications

- Dimensions: conforming to CompactPCI® specification for 3U boards
- Weight: 370g

Environmental Specifications

- Temperature range (operation):
 - 0..+60°C up to -40..+85°C (depending on CPU, SDRAM and hard disk configuration)
 - Airflow: min. 10m³/h (Celeron® M 373); min. 15m³/h (all other processors)
- Temperature range (storage): -40..+85°C
- Relative humidity (operation): max. 95% non-condensing
- Relative humidity (storage): max. 95% non-condensing
- Altitude: -300m to + 3,000m
- Shock: 15g/11ms
- Bump: 10g/16ms
- Vibration (sinusoidal): 2g/10..150Hz
- Conformal coating on request

Safety

- PCB manufactured with a flammability rating of 94V-0 by UL recognized manufacturers

EMC

- Tested according to EN 55022 (radio disturbance), IEC1000-4-2 (ESD) and IEC1000-4-4 (burst) with regard to CE conformity

BIOS

- Award BIOS

Software Support

- Windows®
- Linux
- VxWorks®
- QNX® (on request)
- For more information on supported operating system versions and drivers see Software.

Diagram

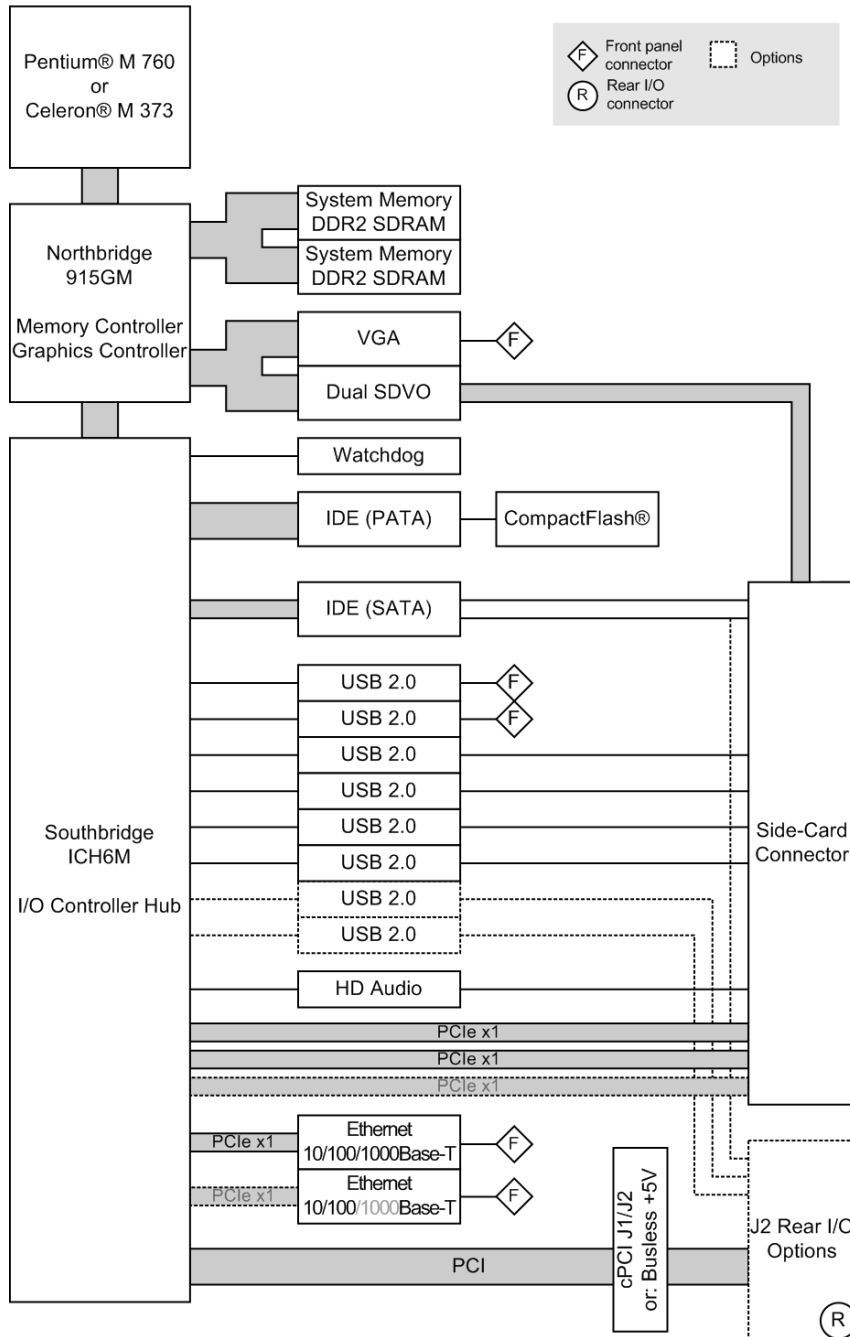

Configuration & Options

Standard Configurations

Article No.	CPU Type	Clock	System RAM	CFlash	Ethernet	RTC	Side Card Slot	Operation Temperature
02F014-00	Celeron® M 373	1 GHz	512 MB	0 MB	1 Gb, 1 Fast Ethernet	GoldCap	right	0..+60°C
02F014-01	Pentium® M 760	2 GHz	1 GB	0 MB	2 Gb Ethernet	GoldCap	right	0..+60°C
02F014-02	Celeron® M 373	1 GHz	512 MB	0 MB	1 Gb, 1 Fast Ethernet	GoldCap	right	-40..+85°C
02F014-13	Pentium® M 760	2 GHz	1 GB	0 MB	2 Gb Ethernet	battery	right	0..+60°C

Options

CPU

- Celeron® M 373 ULV, 1.0GHz
- Celeron® M 370, 1.5GHz
- Pentium® M 738 LV, 1.4GHz
- Pentium® M 745 LV, 1.8GHz
- Pentium® M 760, 2.0GHz

Memory

- System RAM
 - 256 MB, 512 MB, 1 GB or 2 GB
- CompactFlash®
 - 0 MB up to maximum available

Graphics

- One or two DVI-D connectors at front via side card
 - Simultaneous connection of two monitors

I/O

- Ethernet
 - 9-pin D-Sub connector with one or two 10/100Base-T ports instead of two RJ45 connectors

Rear I/O

- One SATA channel (instead of one side-card channel)
- Two USB 2.0 ports

Real-Time Clock

- Buffered by battery instead of GoldCap
 - For retention of time/date data after a power off of more than 8-10 hours. When a 1.8" PATA hard disk is used, no battery can be used on the CPU board

Mechanical

- Side card can be added at left or right side of CPU

Operation Temperature

- 0..+60°C up to -40..+85°C
- Depends on board configuration (CPU, system RAM, hard disk)
- Larger heat sink for special requirements available on request

Please note that some of these options may only be available for large volumes. Please ask our sales staff for more information.

Ordering Information

Standard Hardware

02F014-00	Celeron® M 373, 1GHz, 512MB DDR2 DRAM, 1 Gigabit/1 Fast Ethernet, 0..+60°C
02F014-01	Pentium® M 760, 2GHz, 1GB DDR2 DRAM, 2 Gigabit Ethernet, 0..+60°C
02F014-02	Celeron® M 1GHz, 512MB DDR2 DRAM, 1 Gigabit/1 Fast Ethernet, -40..+85°C
02F014-13	Pentium® M 760, 2GHz, 1GB DDR2 DRAM, 2 Gigabit Ethernet, battery, 0..+60°C

Memory

0751-0023	CompactFlash® card, 2 GB, Type I, -40..+85°C, fixed bit set
0751-0025	CompactFlash® card, 512 MB, Type I, -40..+85°C, removable
0751-0026	CompactFlash® card, 256 MB, Type I, -40..+85°C, removable
0751-0027	CompactFlash® card, 1 GB, Type I, -40..+85°C, fixed bit set
0751-0031	CompactFlash® card, 4 GB, Type I, -40..+85°C, fixed bit set

Systems & Card Cages

0701-0021	CompactPCI® 19" 4U/84HP rack-mount enclosure for 3U cards (vertical), 8-slot 3U CompactPCI® backplane, system slot right, prepared for rear I/O, space for hard-disk drive, floppy drive, CD-ROM drive, 300W ATX power supply wide range 100..240VAC on front, 1U fan tray with 2 fans included
0701-0041	19" 4U/84HP CompactPCI® Express rack-mount enclosure, 8-slot hybrid backplane, space for hard-disk drives, CD-ROM drive, 300W ATX PSU, 1U fan tray with 2 fans included
0701-0046	CompactPCI® 19" 4U/24HP desktop system for 3U cards, 3-slot 3U CompactPCI® backplane, system slot right, 1U fan tray with 1 fan, 8 HP space for 1 pluggable PSU

Miscellaneous

05F601-00	Kit (cable only) for connection of 1 SA-Adapter™ to F601-02, SA-Adapters™ to be ordered separately
0710-0025	SATA hard disk 2.5", 80 GB, 5400 rpm, 24h/7d, -30..+85°C; N.B.: between -30°C to -20°C power-on time is 12 s typ.

0713-0003	CompactPCI® 3U 1-slot backplane for stand-alone operation of F14, F15, F17, F18: 32-bit/33-MHz with rear I/O, 3.3V supply, ATX-power, power, JTAG, IPMB and utility connection, 6x screw connection M3
------------------	--

Software: OS independent

13Y001-06	MDIS4™/2004 low-level driver sources (MEN) for LM63 on SMBus for F14, F15, F17, F18, D9 and D601
13Y002-06	MDIS4™/2004 low-level driver sources (MEN) for F14, F15, F17, F18, D9 and D601 board monitoring
13Y004-06	MDIS4™/2004 low-level driver sources (MEN) for generic SMBus driver for F14, F15, F17, F18, D9, D601, F600 and F601
13Y007-06	MDIS4™/2004 low-level driver sources (MEN) for F14, F15, F17, F18, D9 and D601 board controller

Software: Windows

13F014-77	Windows® driver installation package (MEN) for F14, F15, F17, F18 and D601
13T001-70	Windows® network driver (Intel®) for F14, F15, F17, F18, D9, D6, D7, D601 and P601, P602
13T002-70	Windows® chipset graphics driver (Intel®) for F14 and D601
13T003-70	Windows® chipset driver (Intel®) for F14, F15, F17, F18, D9, D6, D7 and D601
13T005-70	Windows® USB2UART driver (FTDI) for F14, F15, F17, F18 and D9
13T006-70	Windows® HD Audio driver (Realtek) for F14, F15, F17, F18 and D9
13Y001-70	MDIS4™/2004 Windows® driver (MEN) for LM63 on SMBus for F14, F15, F17, F18, D9 and D601
13Y002-70	MDIS4™/2004 Windows® driver (MEN) for F14, F15, F17, F18, D9 and D601 board monitoring
13Y004-70	MDIS4™/2004 Windows® driver (MEN) for SMBus devices for F14, F15, F17, F18, D9, D601, F600 and F601
13Y007-70	MDIS4™/2004 Windows® driver (MEN) for F14, F15, F17, F18, D9 and D601 board controller

Software: VxWorks

10F014-60	VxWorks® BSP (MEN) for F14 and D601
13Y003-60	VxWorks® driver (MEN) for USB-to-UART bridges on F600...F606 and D700

Ordering Information

Software: QNX

10F014-40 QNX® 6.3 installation support files (MEN)
for F14, F15, F17 and D9

Software: Firmware/BIOS

14F014-01 System BIOS for F14 and D601

Documentation

20APPN004 Application Note: How to make a USB stick bootable
20F014-00 F14 User Manual
20F014-ER F14 Errata
21APPN012 Application Note: MDIS™Examples under Linux

For the most up-to-date ordering information and direct links to other data sheets and downloads, see the F14 online data sheet under » www.men.de.

Diamond Point International (Europe) Ltd

Suite 13, Ashford House, Beaufort Court
Sir Thomas Longley Road, Rochester, Kent, ME2 4FA, UK
Phone 01634 300900 - Fax 01634 722398 - Email sales@dpie.com – Web www.dpie.com



www.dpie.com

Germany

MEN Mikro Elektronik GmbH
Neuwieder Straße 5-7
90411 Nuremberg
Phone +49-911-99 33 5-0
Fax +49-911-99 33 5-901
E-mail info@men.de
www.men.de

France

MEN Mikro Elektronik SA
18, rue René Cassin
ZA de la Châtelaine
74240 Gaillard
Phone +33 (0) 450-955-312
Fax +33 (0) 450-955-211
E-mail info@men-france.fr
www.men-france.fr

USA

MEN Micro, Inc.
24 North Main Street
Ambler, PA 19002
Phone (215) 542-9575
Fax (215) 542-9577
E-mail sales@menmicro.com
www.menmicro.com

The date of issue stated in this data sheet refers to the Technical Data only. Changes in ordering information given herein do not affect the date of issue.

All brand or product names are trademarks or registered trademarks of their respective holders.

Information in this document has been carefully checked and is believed to be accurate as of the date of publication; however, no responsibility is assumed for inaccuracies. MEN Mikro Elektronik accepts no liability for consequential or incidental damages arising from the use of its products and reserves the right to make changes on the products herein without notice to improve reliability, function or design. MEN Mikro Elektronik does not assume any liability arising out of the application or use of the products described in this document.

The products of MEN Mikro Elektronik are not suited for use in nuclear reactors and for application in medical appliances used for therapeutical purposes.

Application of MEN's products in such plants is only possible after the user has precisely specified the operation environment and after MEN Mikro Elektronik has consequently adapted and released the product.

Copyright © 2008 MEN Mikro Elektronik GmbH. All rights reserved.



mikro elektronik
gmbh · nürnberg