

F216 - 3U CompactPCI® Octal UART

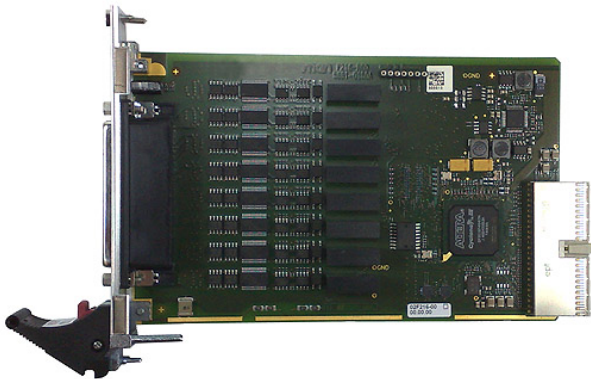

- Octal 16550 UART
- RS232/422/485, isolated
- Large receive and transmit FIFOs
- Very high data rates up to 921,600 bits/s
- Full handshake support
- Hardware flow control for RS485 half duplex
- -40 to +85°C with qualified components

The F216 is an octal UART I/O board based on 3U CompactPCI®. Two UART controllers provide four full-duplex serial channels each. The physical layers are integrated on the board: each of the eight channels can be individually configured as single-ended RS232 or differential RS422 or RS485. The default setting is RS422. The UART controller supports high data rates up to 921,600 bits/s, depending on the physical interface type. Its register set is fully 16550D compatible, even with larger, 60-byte FIFOs. Each channel of F216 has its own 500V isolation, with all ports being available on one 78-pin D-Sub

connector. An adapter cable is also available to spread the 78-pin connector to eight standard 9-pin D-Sub connectors.

The F216 is designed for use in rugged environments. For example, all components are specified for an operation temperature of -40 to +85°C. The card easily expands CompactPCI® systems by an additional eight UARTs on 4 HP where the CPU does not provide enough COM interfaces.

Technical Data

UART Interfaces

- Eight RS232/RS422/RS485 UARTs
- Software-configurable
- Default at start-up: RS422, can be customized through non-volatile state saver
- Two 16Z125_UART controllers with four UARTs each
- Data rates:
 - Up to 921,600 bits/s with RS422/RS485
 - Up to 230,400 bits/s with RS232
- 60-byte transmit/receive buffer
- Handshake lines: full support with RS232
- Full-duplex operation with RS422, half-duplex operation with RS485
- Isolation between channels: 500V
- Accessible on front-panel 78-pin D-Sub connector

Miscellaneous

- Four status LEDs at front panel
 - One status LED to signal FPGA configuration (UARTs ready)
 - Three user LEDs, FPGA-controlled by 16Z034_GPIO controller

Local PCI Bus

- 32-bit/33-MHz, 3.3V V(I/O)
- Compliant with PCI Specification 2.2

CompactPCI® Bus

- Compliance with CompactPCI® Core Specification PICMG 2.0 R3.0
- Peripheral slot
- V(I/O): +3.3V

Electrical Specifications

- Supply voltage/power consumption:
 - +5V (-3%/+5%), 510mA
 - +3.3V (-3%/+5%), 150mA

Mechanical Specifications

- Dimensions: conforming to CompactPCI® specification for 3U boards
- Front panel: 4HP with ejector
- Weight: 182g

Environmental Specifications

- Temperature range (operation):
 - -40..+85°C (qualified components)
 - Airflow: min. 1m/s
- Temperature range (storage): -40..+85°C
- Relative humidity (operation): max. 95% non-condensing
- Relative humidity (storage): max. 95% non-condensing
- Altitude: -300m to + 3,000m

- Shock: 15g/11ms
- Bump: 10g/16ms
- Vibration (sinusoidal): 2g/10..150Hz
- Conformal coating on request

MTBF

- 96,149h @ 40°C according to IEC/TR 62380 (RDF 2000)

Safety

- PCB manufactured with a flammability rating of 94V-0 by UL recognized manufacturers

EMC

- Conforming to EN 55022 (radio disturbance), IEC1000-4-2 (ESD) and IEC1000-4-4 (burst)

Software Support

- Driver software for Windows® (in preparation), Linux, VxWorks®, QNX®
- For more information on supported operating system versions and drivers see Software.

Diagram

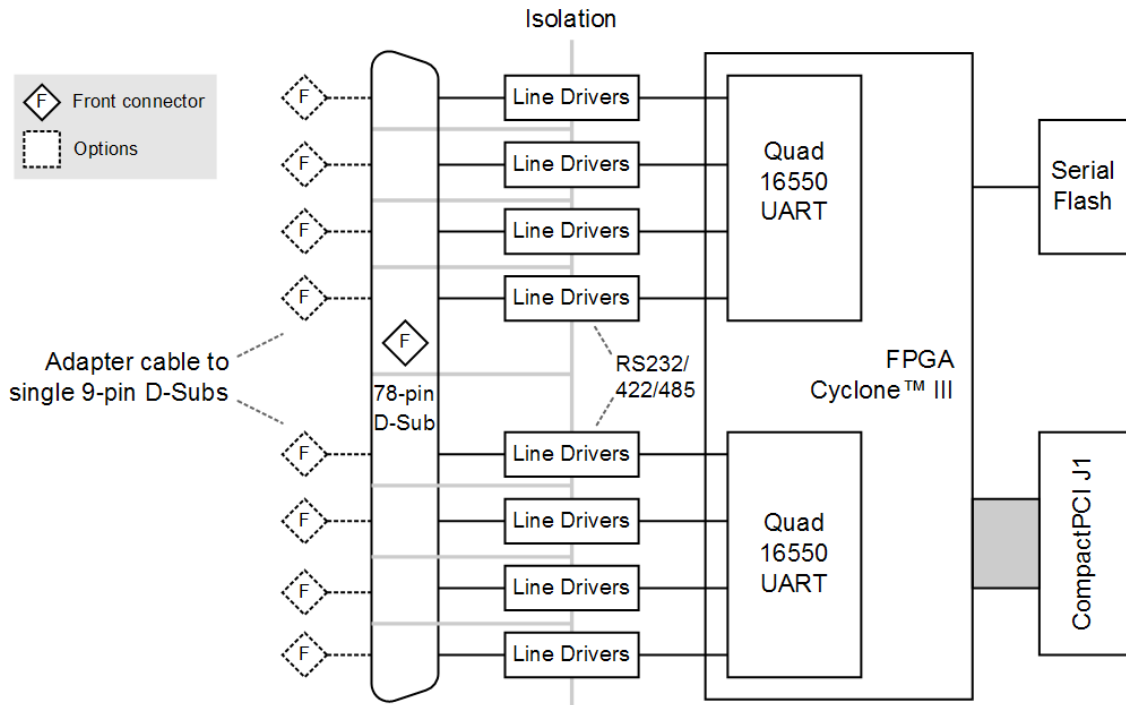

Ordering Information

Standard Hardware

02F216-00 8 serial interfaces via 78-pin D-Sub, RS232/422/485 hardware-configurable, -40..+85°C qualified

Miscellaneous

05F216-00 78-pin HD D-Sub to 8x 9-pin D-Sub cable, 1000 mm, -40..+85°C qualified

Software: OS independent

13Z017-06 MDIS4™/2004 low-level driver sources (MEN) for 16Z034_GPIO and 16Z037_GPIO

Software: Linux

13Z025-90 Linux native driver (MEN) for 16Z025_UART, 16Z057_UART and 16Z125_UART

Software: VxWorks

13Z025-60 VxWorks® native driver (MEN) for 16Z025_UART, 16Z057_UART and 16Z125_UART

Software: QNX

13Z025-40 QNX® native driver (MEN) for 16Z025_UART and 16Z125_UART

Documentation

20F216-00 F216 User Manual

21APPN009 Application Note: 16Z025_UART and 16Z125_UART under Linux

For the most up-to-date ordering information and direct links to other data sheets and downloads, see the F216 online data sheet under » www.men.de.

Contact Information

Germany

MEN Mikro Elektronik GmbH
 Neuwieder Straße 5-7
 90411 Nuremberg
 Phone +49-911-99 33 5-0
 Fax +49-911-99 33 5-901
 E-mail info@men.de
 www.men.de

France

MEN Mikro Elektronik SA
 18, rue René Cassin
 ZA de la Châtelaine
 74240 Gaillard
 Phone +33 (0) 450-955-312
 Fax +33 (0) 450-955-211
 E-mail info@men-france.fr
 www.men-france.fr

USA

MEN Micro, Inc.
 24 North Main Street
 Ambler, PA 19002
 Phone (215) 542-9575
 Fax (215) 542-9577
 E-mail sales@menmicro.com
 www.menmicro.com

Diamond Point International (Europe) Ltd

Suite 13, Ashford House, Beaufort Court
 Sir Thomas Longley Road, Rochester, Kent, ME2 4FA, UK
 Phone 01634 300900 - Fax 01634 722398 - Email sales@dpie.com – Web www.dpie.com www.dpieshop.com



www.dpie.com

The date of issue stated in this data sheet refers to the Technical Data only. Changes in ordering information given herein do not affect the date of issue.

All brand or product names are trademarks or registered trademarks of their respective holders.

Information in this document has been carefully checked and is believed to be accurate as of the date of publication; however, no responsibility is assumed for inaccuracies. MEN Mikro Elektronik accepts no liability for consequential or incidental damages arising from the use of its products and reserves the right to make changes on the products herein without notice to improve reliability, function or design. MEN Mikro Elektronik does not assume any liability arising out of the application or use of the products described in this document.

The products of MEN Mikro Elektronik are not suited for use in nuclear reactors and for application in medical appliances used for therapeutic purposes.

Application of MEN's products in such plants is only possible after the user has precisely specified the operation environment and after MEN Mikro Elektronik has consequently adapted and released the product.

Copyright © 2008 MEN Mikro Elektronik GmbH. All rights reserved.



mikro elektronik
 gmbh • nürnberg