

RC1 - Rugged MIPIOS® Box Computer

miPIOS



The box computer RC1 is a rugged, fanless and maintenance-free panel PC for harsh, mobile, mission-critical applications with visualization requirements in transportation, avionics, industrial automation and medical engineering.

The RC1 is prepared for wall mounting (DIN rail mounting optional). Its robust stainless enclosure is protected against violent impacts and the whole unit waterproof up to 1 m according to IP 67.

The RC1 is controlled by the Intel® Atom™ Z510 running at 1.1 GHz with a performance comparable to a Celeron® M at 1 GHz and higher. It comes with 512 MB of DDR2 SDRAM and 4 GB of USB-driven Flash disk. All I/O signals are concentrated at the front side of the RC1. The interfaces comprise 2 Fast Ethernet (on M12 connectors) and 2 USB ports (one master, one client) combined on an 8-pin M12 connector (also featuring a reset input) as well as two UART (COM) ports on M12 connectors. The FPGA-based concept of the RC1 enables easy implementation of other alternative interfaces in various combinations (e.g. RS422, IBIS, CAN bus). A second power input makes it

- 3.5" TFT LCD panel with touch functionality
- 186mm x 111mm x 85mm housing (tbc.)
- Rugged aluminum enclosure
- Fanless and maintenance-free
- Intel® Atom™ processor 1.1 GHz
- 512 MB RAM, 4 GB Flash Disk
- 2 Fast Ethernet (M12)
- 2 UART (COM, M12)
- 2 USB ports (1 master, 1 client, 8-pin M12)
- Windows® XP Embedded image
- -40 to +70(+85)°C operating temperature
- 2x 24 VDC in (14.4 to 33.6 V)
- Compliant with EN 50155, IP 67 (waterproof up to 1 m)

possible to connect a backup power source (e.g., a battery).

The RC1 is one of the first members of the MIPIOS® family of products, which also includes Ethernet switches (the unmanaged RS1 and the managed RS2) and intelligent I/O modules. It is designed for Ethernet connectivity. A MiniPCI Express® card slot with a SIM card slot in combination with the two Type N antenna connectors can be used to incorporate wireless functions like Bluetooth, WIFI, WIMAX, GSM/GPRS, UMTS etc. With a typical power consumption of only 10 W for the total system the design is always realized without fans, using conductive cooling to spread the dissipated heat to the outside of the housing. All electronic components are soldered to withstand shock and vibration and prepared for conformal coating. The standard version of the RC1 complies with the EN 50155, class Tx railway standard. It is thus for example able to operate in a -40 to +70°C (+85°C for 15 minutes) environment. For applications where visualization is not needed, an RC1 model without a display is also available.

Technical Data

CPU

- Intel® Atom™ Z510
 - 1.1GHz processor core frequency
 - 400MHz system bus frequency

Display

- Screen size
 - 3.5"
- Resolutions
 - 640 x 480
- Visible screen area
 - 75 x 54 mm (tbc.)
- Touch functionality

Memory

- 512MB DDR2 SDRAM system memory
 - Soldered
 - 400MHz memory bus frequency locked to the FSB frequency
- 4GB Flash

I/O

- All I/O available at front of housing
- USB
 - 1 USB 2.0 master port (for diagnostics and service)
 - 1 USB 2.0 client port (for diagnostics and service)
 - Both accessible via the same 8-pin M12 connector
 - UHCI implementation
 - Data rates up to 480Mbits/s
- Reset input
 - Accessible via the same 8-pin M12 connector as the USB ports
- Ethernet
 - Two 10/100Base-T Ethernet channels
 - Accessible via M12 connectors
- UART (COM)
 - Two UART (COM) ports via special D-Sub connectors (waterproof according to IP 67), realized through SA-Adapters™
 - RS232 or RS422, isolated or not, IBIS
 - Data rates up to 230.4kbits/s
 - 16-byte transmit/receive buffer
 - Handshake lines: lines depend on SA-Adapters™
- Two Type N connectors for antenna diversity
 - Adapter with SIM card slot for optional MiniPCI Express® wireless card
 - For WIFI, WIMAX, GSM/GPRS, UMTS etc.
- Power
 - Power Input via M12 connector
 - Backup Power Input via M12 connector

Electrical Specifications

- Isolation voltage:
 - 1500V DC between isolation groups
- Power consumption:
 - 10W typ.
- Supply voltage:
 - 2x 24VDC according to EN50155 (main and backup)
- External power supply (subject to change)
 - tbd., 24VDC out

Mechanical Specifications

- Dimensions: 186mm x 111mm x 85mm (subject to change)
- Prepared for wall mounting
- Weight: tbd.
- Display covered with laminated glass
- Aluminum enclosure
- IP 67 compliant (waterproof up to 1 m)
- Conformal coating on request

Environmental Specifications

- Temperature range (operation):
 - -40°C to +70°C, with up to +85°C for 15 minutes according to class Tx (EN50155)
 - Conductive cooling
 - Fanless operation
- Temperature range (storage): -40..+85°C
- Relative humidity (operation): max. 95% non-condensing (tbd)
- Relative humidity (storage): max. 95% non-condensing (tbd)
- Altitude: -300m to + 3,000m (tbd)
- Shock: according to EN 50155 (10.2.11)(tbd)
- Vibration: according to EN 50155 (10.2.11)(tbd)

MTBF

- tbd. @ 40°C according to IEC/TR 62380 (RDF 2000)

EMC

- Conforming to EN 50155, EN 50121-3-2/EN 61000-4-5

Software Support

- Windows® XP Embedded image included (160-day trial version)
- For more information on supported operating system versions and drivers see Software.

Diagram

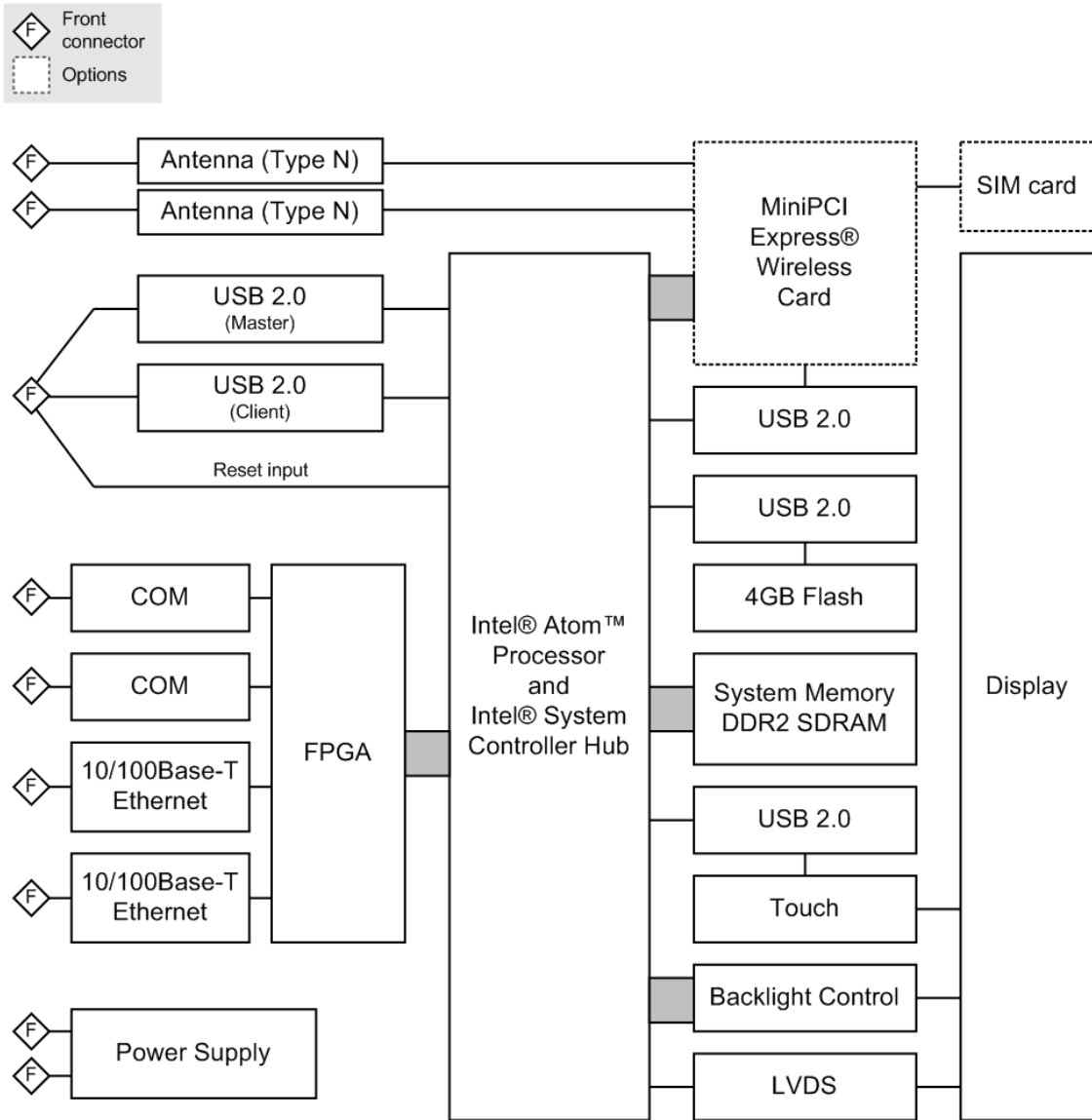

Configuration & Options

Standard Configurations

Article No.	Display
06RC01-00	3.5" TFT LCD with touch functionality
06RC01-01	no display

Options

Wireless functionality

- Bluetooth, WIFI, WIMAX, GSM/GPRS, UMTS etc. via respective MiniPCI Express® wireless card
 - MiniPCI Express® card slot features a SIM card slot

Memory

- Up to 1GB DDR2 SDRAM system memory

I/O interfaces

- Various combinations of interfaces via the two D-Sub ports
 - RS232 (standard, isolated or not)
 - RS422 (isolated or not)
 - IBIS
 - CAN bus
- Alternatively, no D-Sub ports at all

Mechanical Specifications

- Prepared for DIN-rail wall mounting (EN 50022, BS 5584)

Electrical Specifications

- Input voltage 48VDC (18 to 72V)
- Input voltage 110VDC (36 to 154V)

Safety

- Conformal coating

Software

- VxWorks® (on request)
- Linux (on request)
- QNX® (on request)

Contact Information

Germany

MEN Mikro Elektronik GmbH
 Neuwieder Straße 5-7
 90411 Nuremberg
 Phone +49-911-99 33 5-0
 Fax +49-911-99 33 5-901
 E-mail info@men.de
 www.men.de

France

MEN Mikro Elektronik SA
 18, rue René Cassin
 ZA de la Châtelaine
 74240 Gaillard
 Phone +33 (0) 450-955-312
 Fax +33 (0) 450-955-211
 E-mail info@men-france.fr
 www.men-france.fr

USA

MEN Micro, Inc.
 24 North Main Street
 Ambler, PA 19002
 Phone (215) 542-9575
 Fax (215) 542-9577
 E-mail sales@menmicro.com
 www.menmicro.com

The date of issue stated in this data sheet refers to the Technical Data only. Changes in ordering information given herein do not affect the date of issue.

All brand or product names are trademarks or registered trademarks of their respective holders.

Information in this document has been carefully checked and is believed to be accurate as of the date of publication; however, no responsibility is assumed for inaccuracies. MEN Mikro Elektronik accepts no liability for consequential or incidental damages arising from the use of its products and reserves the right to make changes on the products herein without notice to improve reliability, function or design. MEN Mikro Elektronik does not assume any liability arising out of the application or use of the products described in this document.

The products of MEN Mikro Elektronik are not suited for use in nuclear reactors or for application in medical appliances used for therapeutical purposes.

Application of MEN's products in such plants is only possible after the user has precisely specified the operation environment and after MEN Mikro Elektronik has consequently adapted and released the product.

Copyright © 2009 MEN Mikro Elektronik GmbH. All rights reserved.