

P511 - Dual Fast Ethernet PMC

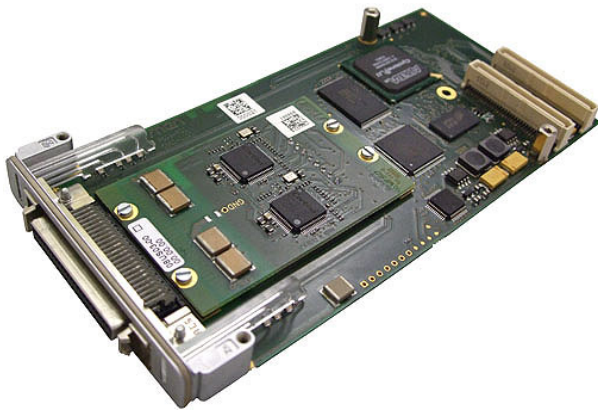

- **2 full-duplex or half-duplex channels**
- **10Base-T and 100Base-TX physical layer**
- **MAC layer realized in FPGA**
- **Local or external data buffer**
- **6 additional GPIOs**
- **Fully integrated to comply with IEEE802.3**
- **1500 VAC isolation voltage**
- **-40 to +85°C with qualified components**
- **32-bit/33-MHz PMC**
- **PMC based on USM™ concept**
- **Individual FPGA configuration**

The P511 is a 32bit/33MHz PMC with dual Ethernet functionality. The two channels can be accessed via two RJ45 connectors which are led to the front via an adapter cable from a SCSI connector. They support half duplex and full duplex operation.

The PMC offers the possibility to buffer all receive and transmit Ethernet frames either in a local or in an external data buffer. This makes it possible to provide a Worst Case Execution Time analysis which makes it particularly well suited for safety-critical applications.

Up to 6 GPIO lines can be used on the module for additional functionality.

The P511 is based on the USM™ concept. USM™ Universal Submodules make PMC modules more flexible than ever. The Ethernet functionality is realized

via an IP core implemented inside its onboard FPGA. This function can be changed at any time through implementation of different IP cores. The corresponding line drivers are realized on the USM™ which is simply plugged on the P511. One alternative function is the combination of an Ethernet core with a fieldbus interface to build gateways.

The module is suitable for any PMC compliant host carrier board in any type of bus system, i.e. CPCI, VME or on any type of stand-alone SBC in telecommunication, industrial, medical, transportation or aerospace applications. It offers long-term availability for at least 10 years and is qualified for operation in the extended temperature range.

Technical Data

Ethernet Interface

- Two 10/100Base-T Ethernet channels
- Accessible on two RJ45 connectors via adapter cable
- Half duplex/full duplex support

Memory

- 32MB SDRAM memory
 - Soldered
 - DDR2
 - 132MHz memory bus frequency
 - FPGA-controlled
- 2MB non-volatile Flash
 - For FPGA data and Nios® firmware
 - FPGA-controlled

Up to six GPIO lines

- Controlled via software

FPGA

- Standard factory FPGA configuration:
 - Main bus interface
 - Interrupt controller, SMBus controller
 - 16Z087_ETH - Ethernet MAC IP core (2 IP cores for the 2 channels)
 - 16Z043_SDRAM - SDRAM controller
 - 16Z045_FLASH - Flash interface
 - 16Z034_GPIO - GPIO controllers (2 IP cores, for onboard LEDs and 8-bit I/O)
- The FPGA offers the possibility to add customized I/O functionality. See FPGA.

PMC Characteristics (PCI)

- Compliant with PCI Specification 2.2
- 32-bit/33-MHz, 3.3V V(I/O)
- Target and initiator

Peripheral Connections

- Via front panel on a shielded 50-pin HP D-Sub SCSI 2 receptacle connector
- Adapter cable to two RJ45 connectors included in the delivery

Electrical Specifications

- Isolation voltage:
 - 1500 VAC
- Supply voltage/power consumption:
 - +5V (-3%/+5%), tbd
 - +3.3V (-5%/+5%), tbd

Mechanical Specifications

- Dimensions: conforming to IEEE 1386.1
- Weight: tbd

Environmental Specifications

- Temperature range (operation):
 - -40..+85°C (qualified components)
 - Airflow: min. 1.0m/s
- Temperature range (storage): -40..+85°C
- Relative humidity (operation): max. 95% non-condensing
- Relative humidity (storage): max. 95% non-condensing
- Altitude: -300m to + 3,000m
- Shock: 15g/11ms
- Bump: 10g/16ms
- Vibration (sinusoidal): 1g/10..150Hz
- Conformal coating on request

MTBF

- tbd @ 40°C according to IEC/TR 62380 (RDF 2000)

Safety

- PCB manufactured with a flammability rating of 94V-0 by UL recognized manufacturers

EMC

- Conforming to EN 55022 (radio disturbance), IEC1000-4-2 (ESD) and IEC1000-4-4 (burst)

Software Support

- Windows® (in preparation)
- Linux (in preparation)
- For more information on supported operating system versions and drivers see Software.

Diagram

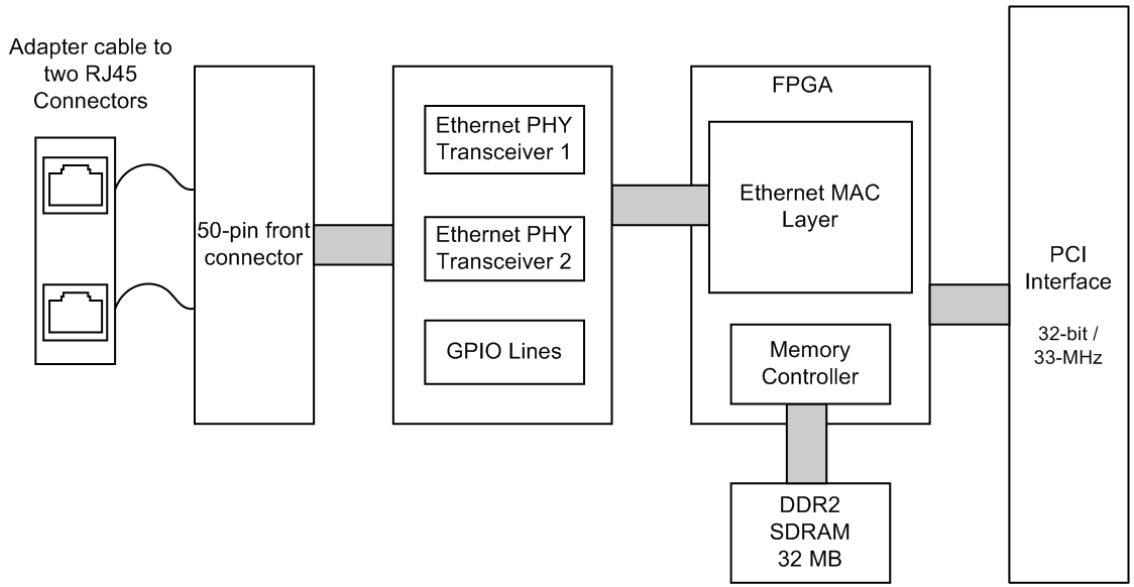

Configuration & Options

Standard Configurations

Article No.	Main FPGA Content	Soft Core	Memory	Signals	Cooling Method	Operation Temperature
15P511-00	2 Fast Ethernet Cores	No	32 MB RAM, 2 MB Flash	Front	Convection	-40..+85°C

Options

CPU

- Nios® soft core implementation possible (e.g. for real-time Ethernet)

Rear I/O

- Via Pn4 rear I/O connector

Cooling

- Conduction Cooling

Please note that some of these options may only be available for large volumes. Please ask our sales staff for more information.

FPGA

Flexible Configuration

- This MEN board offers the possibility to add customized I/O functionality in FPGA.
- It depends on the board type, pin counts and number of logic elements which IP cores make sense and/or can be implemented. Please contact MEN for information on feasibility.
- [You can find more information on our web page "User I/O in FPGA"](#)

FPGA Capabilities

- FPGA Altera® Cyclone® II EP2C35
 - 33,216 logic elements
 - 483,840 total RAM bits
 - Supports Nios® II soft processor
- Connection
 - Functions can be linked to Wishbone or Avalon® bus
 - Available pin count: 46 pins (FPGA to USM™)
 - Functions available via USM™ at front I/O connector
- [MEN offers a USM™ development kit and an FPGA Development Package as well as Flash update tools for different operating systems.](#)

Ordering Information

Standard Hardware

15P511-00 Dual Fast Ethernet, 2 Ethernet cores, 6 GPIO signals, front I/O, for convection cooled systems, -40..+85°C with qualified components

Software: Linux

13Z077-90 Linux native driver (MEN) for 16Z077_ETH and 16Z087_ETH

For the most up-to-date ordering information and direct links to other data sheets and downloads, see the P511 online data sheet under » www.men.de.



www.dpie.com

Diamond Point International (Europe) Ltd

Suite 13, Ashford House, Beaufort Court

Sir Thomas Longley Road, Rochester, Kent, ME2 4FA, UK

Phone 01634 300900 - Fax 01634 722398 - Email sales@dpie.com – Web www.dpie.com

Germany

MEN Mikro Elektronik GmbH
Neuwieder Straße 5-7
90411 Nuremberg
Phone +49-911-99 33 5-0
Fax +49-911-99 33 5-901
E-mail info@men.de
www.men.de

France

MEN Mikro Elektronik SA
18, rue René Cassin
ZA de la Châtelaine
74240 Gaillard
Phone +33 (0) 450-955-312
Fax +33 (0) 450-955-211
E-mail info@men-france.fr
www.men-france.fr

USA

MEN Micro, Inc.
24 North Main Street
Ambler, PA 19002
Phone (215) 542-9575
Fax (215) 542-9577
E-mail sales@menmicro.com
www.menmicro.com

The date of issue stated in this data sheet refers to the Technical Data only. Changes in ordering information given herein do not affect the date of issue.

All brand or product names are trademarks or registered trademarks of their respective holders.

Information in this document has been carefully checked and is believed to be accurate as of the date of publication; however, no responsibility is assumed for inaccuracies. MEN Mikro Elektronik accepts no liability for consequential or incidental damages arising from the use of its products and reserves the right to make changes on the products herein without notice to improve reliability, function or design. MEN Mikro Elektronik does not assume any liability arising out of the application or use of the products described in this document.

The products of MEN Mikro Elektronik are not suited for use in nuclear reactors or for application in medical appliances used for therapeutical purposes.

Application of MEN's products in such plants is only possible after the user has precisely specified the operation environment and after MEN Mikro Elektronik has consequently adapted and released the product.

Copyright © 2009 MEN Mikro Elektronik GmbH. All rights reserved.



mikro elektronik
gmbh · nürnberg