

### **CFast™ – Evolution of the CompactFlash® Interface**

*April 14, 2008*

#### **Introduction**

Fourteen years into its existence, CompactFlash® (CF) has established itself as a dominant flash memory card technology in applications where small form factor, low-power dissipation and ease-of-design are crucial considerations. CF Storage Cards provide the capability to transfer all types of digital information and software between a variety of digital systems and are compatible with future CF designs, eliminating interoperability issues. As a result, CF is a powerful solution that can be found in digital SLR cameras, handheld PCs and industrial applications, such as embedded systems, single-board computers and data recorders.

Yet the industry has now approached an inflection point in the adoption of CF. Its parallel interface has delivered performance, form factor and a cost point that has made it a widely adopted flash memory-card format—the de facto standard in high end digital imaging and the dominant SSD in industrial applications. But the methodical march of electronics design has opened the door to an evolution of the standard, one that echoes the parallel-to-serial shift in rotating media years ago.

To inject new life into what is the oldest, most established flash form factor available, the CompactFlash Association (CFA) is now evolving the familiar card architecture with a serial interface, based on the workhorse Serial Advanced Technology Attachment (SATA) specification that has served the disk drive industry so well. This evolution has yielded CFast™, a new specification that leverages the nearly decade of experience the SATA interface has in rotating media. That experience and history will make the transition straightforward for adopters. The new CFast specification, which is the combination of CF and ATA Serial Transport (AST), will enable new applications in embedded and industrial markets, where flexibility, speed and SATA are important design considerations. But before exploring those applications, it is important to understand the interface's evolution and the importance of SATA.

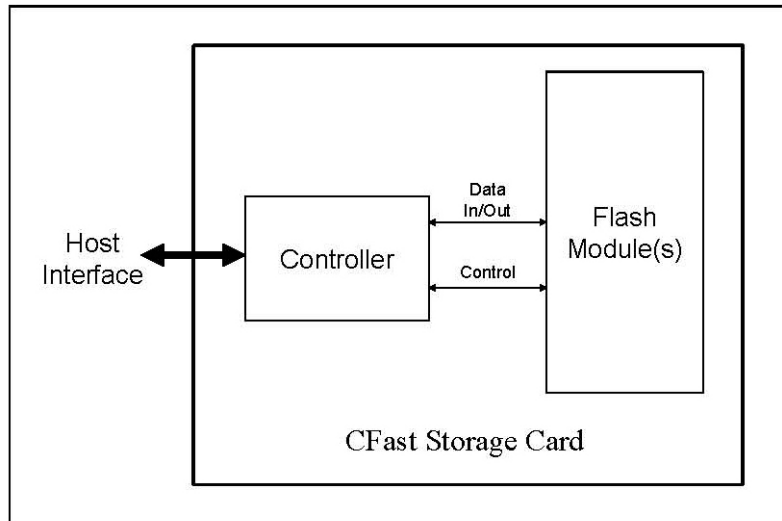

Figure 1: CFast Storage Card Block Diagram

### **Why Evolve CF from PATA to SATA?**

SATA appeared on the scene eight years ago, but was not immediately embraced. While it was a faster alternative to the venerable parallel version, it was more expensive due to the relative low unit volume. The older Parallel ATA (PATA) was well-known and adhered to the strict cost-management dictates of the disk-drive business and their customers, the PC OEMs. But eventually, as drive capacity became denser, the transfer speed of PATA could not keep up with the need to push large quantities of bits on and off the media. PATA topped out at 133 MB/second throughput, while SATA 1.5Gb/sec offered 150MB/sec and SATA 3.0Gb/sec offered 300GB/sec.

Another important feature of SATA that makes it an important evolutionary step for CF is the hot-swap functionality. CFA developed CFast to retain the CF form-factor while increasing the performance of the host interface to accommodate the needs of faster storage. Other benefits include:

- Intelligent power management for lower power consumption
- SATA's existing infrastructure
- Higher performance serial interface for faster data transfer

### **Which Markets Will Initially Benefit Most from CFast?**

CFast, which is not backward compatible with the existing CF format, will be attractive in markets where performance and system downtime are major considerations, i.e. industrial and enterprise storage systems. These markets are also now adopting SATA disk drives and CFast will leverage this trend providing for quick adoption and seamless integration, resulting in little risk for designers looking to adopt the technology. Designing with CFast

requires no new debugging steps, as SATA has been fully debugged in the past five years. Also, the same connector technology is used for CFast as for disk drives and no new drivers are needed for CFast.

Applications that demand low power (CF consumes less than 5 percent the power of 1.8- and 2-inch disk drives) and reliability will also migrate quickly to CFast (for example switches or servers). In a world in which “five nines” systems are down only 5 minutes a year, the reliability and hot-swap features of CFast are attractive. In rugged environments, the format retains the durability of the original CF device, which specifies an operating shock rating of 2,000 Gs, which is equivalent to a 10-foot drop. The SATA-based architecture and roadmap further makes CFast technology attractive to industrial and enterprise storage system designers, who have long product cycles. Many industrial systems currently support a mix of CF and SATA subsystems, and a shift to CFast would greatly simplify their architectures.

And as the disk drive industry ends manufacturing of PATA drives, CFast becomes an attractive and less-expensive alternative to SATA hard drives. Many designers are looking for only a few hundred megabytes of storage, but with SATA they need to use drives that hold hundreds of gigabytes. While flash may be more expensive on a per-byte basis, the CFast card solution in this case is less expensive.

While these new applications are poised to embrace CFast, digital imaging may also benefit from the technology in the future. The standard and its infrastructure will be well established, and its cost will be dropping by the time the imaging industry is ready to make the shift, a design transition that generally takes two to three years.

### **Key CFast Facts for System Designers**

CFast is a small form factor card standard that encompasses CFast semiconductor (Flash) data storage cards and magnetic disk cards. The CFast card provides high capacity data storage that electrically complies with the Serial ATA International Organization standard. The CFast card uses the same commands, but implements additional control signals on the power connector to manage activity LED, write protect and power down/up of the SATA PHY.

The CFast Storage Card contains a single-chip controller and flash memory module in a matchbook-sized package. The ***Type I CFast card dimensions are 36.4 x 42.8 x 3.3mm; the Type II form factor is 36.4 x 42.8 x 5.0mm.*** The card’s 7+17-pin connector consists of a SATA-compatible 7-pin signal connector and a 17-pin power and control connector. The controller interfaces with a host system allowing data to be written to and read from the flash memory module(s).

#### **Type I CompactFlash Storage Card and CF+ Card Physical Specifications**

<b>Length:</b>	36.4 ± 0.15 mm (1.433 ± .006 in.)
----------------	-----------------------------------

<b>Width:</b>	42.80 ± 0.10 mm (1.685 ±.004 in.)
<b>Thickness Including Label Area:</b>	3.3 mm ± 0.10 mm (.130 ± .004 in.)

### Type II CompactFlash Storage Card and CF+ Card Physical Specifications

<b>Length:</b>	36.4 ± 0.15 mm (1.433 ±.006 in.)
<b>Width:</b>	42.80 ± 0.10 mm (1.685 ±.004 in.)
<b>Thickness Including Label Area:</b>	5.0 mm maximum (.1968 in. maximum)

The **CFast card operates at 3.3V**, plus or minus 5 percent and adheres to three SATA power-management states: 1) Active, 2) Partial, and 3) Slumber

The sleep state may be entered into from the slumber state only. It enters sleep state not more than 10 milliseconds after the CDI pin input is asserted. When the CDI input changes from logic level “1” to logic level “0” (deasserted), and stays at that level for 1 millisecond at least, the CFast card will be back to slumber state in 20 milliseconds at the most (21 milliseconds total).

In the sleep state, the device can turn off the PHY on the SATA interface, if the host also turns off the PHY on its SATA interface, the power savings can be significant. Note that CFast and SATA IO devices are interchangeable as long as this functionality is not required.

Maximum input current on the card ranges from **500mA at Power Level 0** to **1200mA at Power Level 1**. The CFast standard specifies limits to the total amount of current used by the device – which is not part of the SATA IO standard.

The rails of the CFast card and connector are different from a CF card so that you cannot insert a CFast card into a CF slot and vice versa.

### **Conclusion**

As flash memories get denser and prices continue to decline due to Moore’s Law, a new class of applications is poised to migrate to CFast. Its reliability, form factor and environmental toughness are prized in many embedded and industrial computer applications. CFast brings designers a familiar SATA-based storage specification that offers hot swappability for maximum system uptime; an existing infrastructure, including tools and institutional knowledge that will speed design; intelligent power management for lower power consumption; and higher performance for faster data transfer. These features will be certain to attract designers now and into the future as they further understand the features, benefits and historic precedent that pave the way for this transition.

For more information on the CFast interface, please visit [www.compactflash.org](http://www.compactflash.org)

For more information on Serial ATA Revision 2.6, visit Serial ATA International Organization at [www.serialata.org](http://www.serialata.org)

**Reprinted from a CompactFlash Association article of the same title, 14 April 2008.**

