



# C103

## Low Power 750GX PPC® VME SBC

---



- Best Performance per Power Consumption PowerPC® SBC Currently Available (Less than 17 W @ 800MHz)
- Rugged 6U VME Single-Slot SBC
- PowerPC® 750GX up to 800 MHz Processor
- On-chip 32 kB L1 and 1 MB L2 Caches
- Up to 1 GB of SDRAM with ECC
- 32 MB Boot Flash Memory
- 128 MB User Flash Memory
- Up to 2 GB Flash File Memory
- 32 kB NVRAM
- 8 High Performance DMA Engines
- Gigabit Ethernet Port
- Two Fast Ethernet Ports
- Two 1394a FireWire Ports
- Two USB 2.0 Ports
- Two Dual Redundant MIL-STD-1553B Ports
- Six Multi-Protocol High-Speed Serial Ports Supporting RS-232/422/485
- Two Standard UART Ports Supporting RS-232/422/485
- 16 Single Ended TTL/8 Differential RS-422 Discrete I/O Lines
- Two IEEE 1386-2001 or ANSI/VITA 20-2001 Compliant PMC Slots
- Eight 32-bit Timers
- Watchdog Timer
- Real Time Clock
- Fully VME64x Compliant
- WindRiver VxWorks® RTOS Support
- Conduction and Air Cooled Versions
- Vibration and Shock Resistant

---

### Aitech Defense Systems, Inc.

A member of the Ai-Rugged Group

9301 Oakdale Ave, Chatsworth, Ca 91311

Tel: (888) Aitech-8 (248-3248) Fax: (818) 718-9787 e-mail: sales@rugged.com web: www.rugged.com



## C103 Exceptional Performance at Low Power Consumption

The C103 is a low power derivative of the Aitech powerful C100 VME SBC. The C103 provides unmatched performance per power consumption combined with versatile and flexible I/O capabilities for harsh environment applications. Powered by IBM 750GX advanced low power PowerPC<sup>®</sup> microprocessor and integrated on-chip L1 and L2 caches, the C103 provides extremely high processing capabilities.

To further support the high performance processor a large and fast SDRAM array is also implemented in the C103. Additional memory arrays are provided, such as Flash for user application storage, high-density Flash File for mass storage purposes and NVRAM for user/application specific parameters storage.

In addition to its high performance processor architecture the C103 provides unparalleled I/O capabilities all integrated on board. I/O interfaces include three Ethernet ports (one Gigabit and two Fast Ethernet ports), two dual redundant MIL-STD-1553B interfaces, two IEEE1394a (FireWire) ports, two USB 2.0 ports, eight serial ports (six of which are high-speed ports and two are standard UART ports) and up to 16 general-purpose discrete I/O channels.

To complete its extensive capabilities and further expand them, the C103 is equipped with 2 PMC slots allowing installation of additional modules on top.

The C103 internal architecture is based on two separate PCI buses, one operating at 66 MHz while the other at 33 MHz, allowing separation of the slow PCI devices from the faster ones and thus enabling each PCI device to operate at its top speed. In order to achieve maximum bus utilization multiple advanced programmable DMA engines are available for data transfer over the PCI buses.

The C103 implements a compliant VME64x interface using Tundra's Universe II PCI to VME Bridge.

The C103 highly integrated design guarantees unmatched performance and versatility currently available on any rugged conduction or air-cooled PowerPC<sup>®</sup> VME SBC.

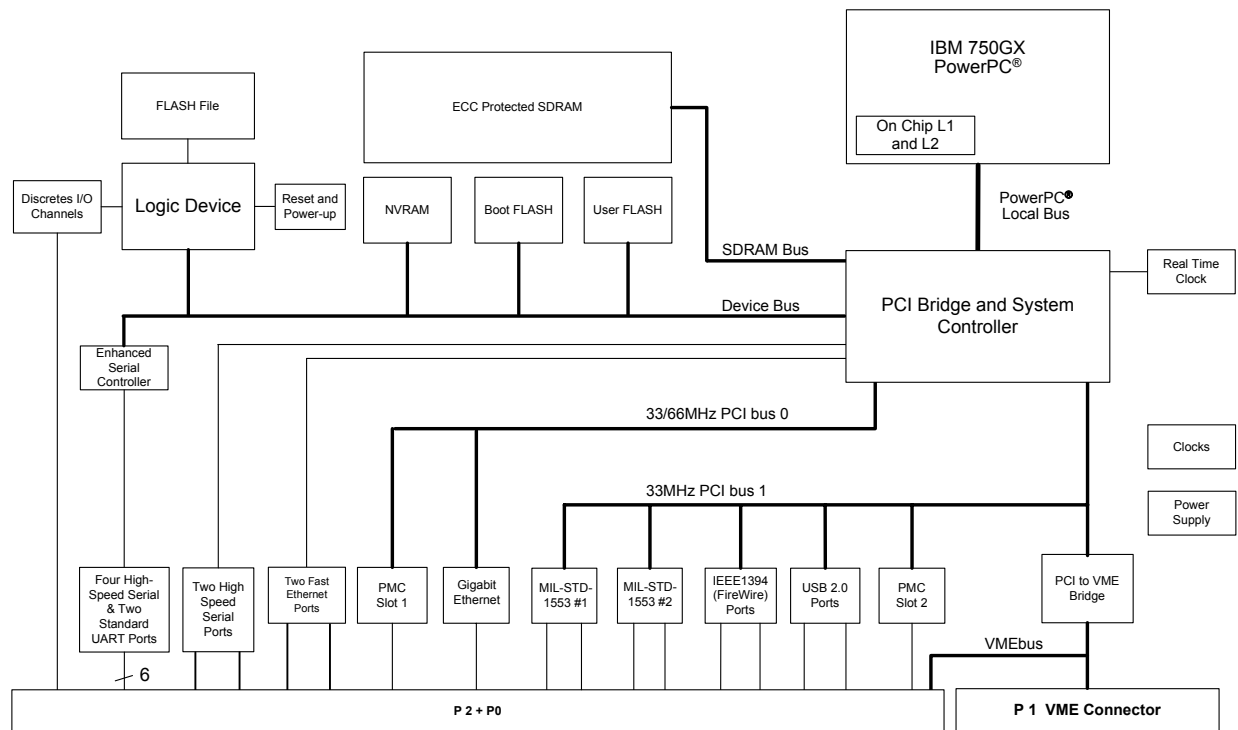

C103 Block Diagram



---

## Functional Description

### Processor and Bus Architecture

The C103 is a powerful processing platform on one hand with ultra low power on the other. This is achieved by combining a high performance low power processor and extensive supporting memory arrays. The board's architecture was designed to maximize utilization of all bus interfaces.

#### Processor

The C103 features the high performance low power IBM 750GX PowerPC® processor. The IBM 750GX is a 32-bit processor integrating both L1 (32kB instruction/data) and L2 (1 MB) caches on chip to support its processing core.

#### Bus Architecture

In order to support the processing unit high performance and to provide a fast highway for data transfer, the C103 implements the advanced highly integrated Discovery™ device.

The Discovery™ is a system controller performing as both the memory controller for the processor and as its bridge to the PCI bus. The Discovery™ system controller interfaces the processor through the 60x bus at 133 MHz.

To maximize PCI bus utilization and allow different PCI bus configuration, the C103 architecture was designed with two separate and totally independent PCI buses.

Both PCI buses support 64-bit operation and fully comply with PCI Rev. 2.2. The first PCI bus is capable of 33/66 MHz operation (depending on the operation capability of the PMC inserted in PMC slot 1) while the second PCI bus is operating at 33 MHz only. This allows separating fast PCI devices from slow ones and each I/O device to operate at its maximum operation speed.

#### Memory

The C103 is equipped with large memory arrays providing the user with extensive resources. These arrays include up to 1 GB fast SDRAM operating at 133 MHz, 32 MB linear Boot Flash, 128 MB linear Flash and up to 2 GB Flash File for solid-state mass storage applications.

All SDRAM banks are ECC protected providing high data integrity.

In addition, the C103 provides a 32 kB NVRAM (Non-Volatile RAM). This array is a fast Flash shadow type of RAM and does not require an external power supply to maintain its contents during power down.

Another Flash array is dedicated to Firmware storage freeing all the other arrays for user applications only.

### VME

The C103 includes a Universe II PCI-VME Bridge device to allow interface between the local PCI architecture and the VME backplane.

The VME interface provides full master and slave capabilities and supports the following:

- A32/A24/A16 addressing modes
- MBLT/BLT/D64/D32/D16/D8 data transfer modes
- Interrupter and handler capability on all seven VME interrupt lines
- Four mailbox and four location monitors for in system board communication
- Full system controller functionality
- Flexible register set allowing manipulation of all VME options

The Universe II Bridge integrates large FIFOs for optimal usage of the two buses on which it resides (PCI and VME). In addition, it includes a DMA engine supporting high data rate transfer. The Bridge is capable of 64-bit at 33 MHz PCI bus operation.

### I/O Interfaces

In addition to its superior processing power and the more traditional serial I/O capabilities such as the Ethernet ports and serial channels, the C103 offers advanced serial I/O interfaces such as FireWire and USB. This enables the communication with hosts supporting these protocols and the attachment of advanced fast peripherals and storage devices.

### MIL-STD-1553B

The C103 provides two on board dual redundant MIL-STD-1553B ports. These ports are implemented through two separate PCI controllers allowing 32-bit at 33 MHz PCI bus operation. Each of the MIL-STD-1553B ports is capable of BC, RT and MT operation.

The MIL-STD-1553B ports are routed to the VME P2 connector via transformer coupling (default) or direct coupling (optional).

### Ethernet

The C103 provides three Ethernet ports, a Gigabit Ethernet and two Fast Ethernet ports. The Gigabit Ethernet interface supports 10BaseT/100BaseTX/1000BaseT and the Fast Ethernet ports support 10BaseT/100BaseTx.

The Gigabit Ethernet controller is capable of 64-bit at 66 MHz PCI operation and resides on the fast PCI bus. This fast interface incorporates large FIFOs and a

---



powerful DMA engine allowing high bandwidth for data transfer.

The fast Ethernet Controllers are integrated in the Discovery™ device allowing fast access to the local SDRAM without loading any of the PCI buses.

### Serial I/O

The C103 provides eight serial ports supporting RS-232/422/485 physical interfaces.

Six of these channels are high-speed multi-protocol synchronous/asynchronous ports supporting all common serial communications protocols (UART, SUART, SDLC, HDLC, BISYNC, Transparent, etc.)

The other two ports are standard asynchronous UART ports.

### IEEE1394a (FireWire)

The C103 provides a high performance IEEE1394a (FireWire) controller. This interface is a widely used protocol enabling data traffic of 100, 200 and 400Mbps. The interface device integrates both the controller and the physical layer. It incorporates large FIFOs and advanced DMA engines for high speed data streaming and full PCI bus utilization.

### USB

These USB protocol is another widely used interface supported by the C103. The board includes a USB Rev. 2.0 host controller (backward compliant with Rev. 1.0 and Rev. 1.1) providing two EHCI/OHCI Root hubs. The controller integrates the USB transceivers supporting high-speed, full-speed and low-speed signaling. The C103 is capable of providing power to down stream devices. The controller is a PCI device capable of high data transfer rates through the use of its internal FIFOs and DMA engine.

### Discrete I/O

In addition to its serial I/O capabilities the C103 is equipped with up to 16 single-ended or 8 differential general-purpose Discrete I/O channels. The discrete I/O comprises two 8-channel groups. Each of these groups may be configured as single ended TTL channel or differential RS-422 channel. Each channel may be independently configured as input or output. Configured as input each of these channels may be programmed to generate an interrupt on any level shift event.

### PMC I/O Expansion

The C103 provides two IEEE 1386-2001 or ANSI/VITA 20-2001 compliant PMC expansion slots for extended flexibility and integration of additional I/O to the board.

Each of the PMC slots resides on a different PCI bus. PMC slot 1 is located on the fast PCI bus supporting 64-bit at 66MHz bus operation. PMC slot 2 is located on the slow PCI bus supporting 64-bit at 33MHz bus operation.

Both PMC slots are capable of hosting IEEE1386/1386.1-2001 compliant air-cooled and VITA 20-2001 compliant conduction-cooled PMC modules.

PMC slot 1 supports 3.3V PCI signaling levels and is 5.0V tolerant allowing insertion of any PMC module. The keying for this slot is universal (no key).

PMC slot 2 supports 5.0V PCI signaling levels only. 3.3V only PMC may not be installed in this slot. Keying at this slot allows the insertion of PMC modules capable of 5.0V PCI signaling levels.

### I/O Routing

All the I/O interfaces signals are available at the C103 P2 and P0 VME rear panel connectors. These I/O interfaces require more I/O than is available at the VME connectors; therefore some I/O configurations are available. For more information please contact an Aitech Systems representative.

On air-cooled versions, some of the I/O interfaces at the front panel. Refer to the front panel section for more information.

### Transition Module

For convenient connection to the C103 I/O interfaces a transition module is available from Aitech.

The **TM100** transition module provides accessibility to all C103 I/O interfaces and eliminates the need for any custom made harnessing and complex cabling fixtures.

It also provides easy access to PMC I/O for PMC cards installed on top the C103. The **TM100** may be installed into air-cooled chassis supporting either front and rear plug-in units or front plug-in units only.

For more information on the **TM100**, refer to its product datasheet.

### Timers

The C103 is equipped with eight 32-bit timers/counters. These timers provide high-resolution timing functionality as well as capability for long interval counting applications.

The C103 includes a Real-Time Clock (RTC) for time and date storage. The RTC is backed up by a large super-capacitor for long-term parameters storage.

A watchdog timer is also available on board the C103. This timer may be programmed for the required time out interval after which it will reset the board.



## Front Panel Connectors and Switches

The air-cooled version of the board is provided with a front panel. The front panel includes the following:

- D-Type connector delivering 2 UART ports
- RJ-45 providing a single Ethernet port
- Reset Switch

## Software

### Test and Diagnostic Features

The C103 is supplied with an extensive firmware package. This package includes startup firmware (boot software), AIMon monitor/debugger tool, AIDiag diagnostic tool, and BIT. BIT may be executed during power-up or at any time after the board has been booted.

The C103 provides a COP/JTAG interface to the processor for debugging and development purposes.

### Operating Systems

The C103 is supplied with a complete Board Support Package (BSP) for WindRiver VxWorks.

Other Real-Time operating systems (RTOS) support may be available upon request.

The BSP includes drivers for all on board resources allowing the user to take full advantage of the board's powerful features.

## Mechanical Features

The C103 is available in two mechanical formats:

- Air-cooled per ANSI/VITA 1-1994
- Conduction cooled per IEEE 1101.2

Both mechanical formats are single slot 6U modules.

Custom metal frame provides excellent rigidity and shock resistance. In addition, a custom metal frame provides an array of stiffeners to support rugged PMC boards.

## Dimensions

- Air-cooled: per ANSI/VITA 1-1994
- Conduction cooled: per IEEE 1101.2

## Weight

Air-cooled form factor: < 625g (1.38 lbs)  
Conduction-cooled form factor: < 750g (1.65 lbs)

## Thermal Management

A careful mechanical design including custom Heatsink modules combined with a metal frame allows optimal heat dissipation and relief of the board.

## Power Requirements

The low power C103 may be configured to receive all its power from the VME backplane +5.0V supply and generate +3.3V using on board power circuits or it may be configured to take the +3.3V also from the backplane supply as defined in the VME64x specification.

Total power consumption of the C103 depends on its configuration and assembly options.

Fully featured with a 800 MHz PowerPC CPU and configured to operate from the +5.0V power supply alone, power consumption of the C103 is as follows:

+3.3V	(± 5%)	0A	
+5.0V	(± 5%)	3.1A (typ)	3.4A (max)
+12V	(± 10%)	0A	
-12V	(± 10%)	0A	

## Environmental Features

Please Refer to the Aitech Ruggedization Datasheet.



## Ordering Information for the C103

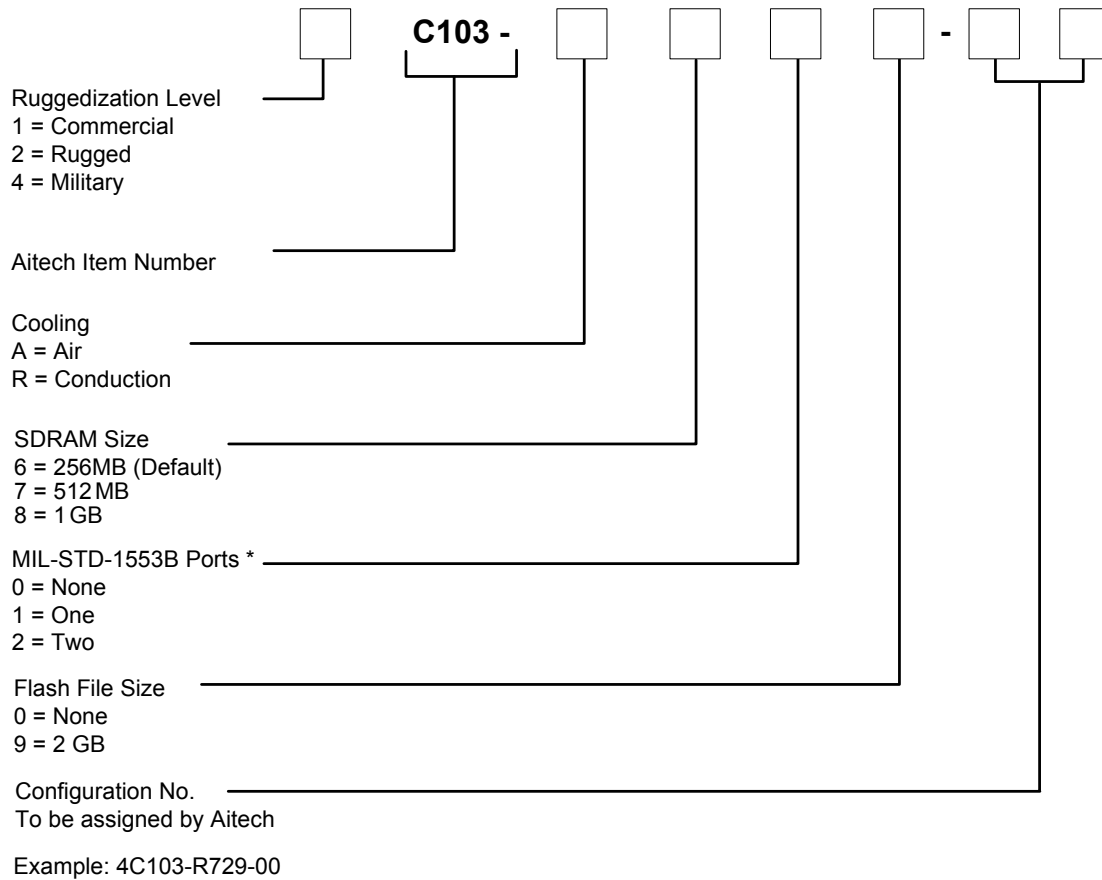

\* Default configuration of MIL-STD-1553B controllers is transformer coupled. Direct coupling is optionally available.



[www.dpie.com](http://www.dpie.com)

### **Diamond Point International (Europe) Ltd**

Suite 13, Ashford House, Beaufort Court  
Sir Thomas Longley Road, Rochester, Kent, ME2 4FA, UK  
Phone 01634 300900 - Fax 01634 722398 - Email [sales@dpie.com](mailto:sales@dpie.com) – Web [www.dpie.com](http://www.dpie.com)

All names, products, and/or services mentioned are trademarks or registered trademarks of their respective holders.  
All information contained herein is subject to change without notice.

C103T0206R19

### **Aitech Defense Systems, Inc.**

A member of the Ai-Rugged Group  
9301 Oakdale Ave, Chatsworth, Ca 91311  
Tel: (888) Aitech-8 (248-3248) Fax: (818) 718-9787 e-mail: [sales@rugged.com](mailto:sales@rugged.com) web: [www.rugged.com](http://www.rugged.com)