

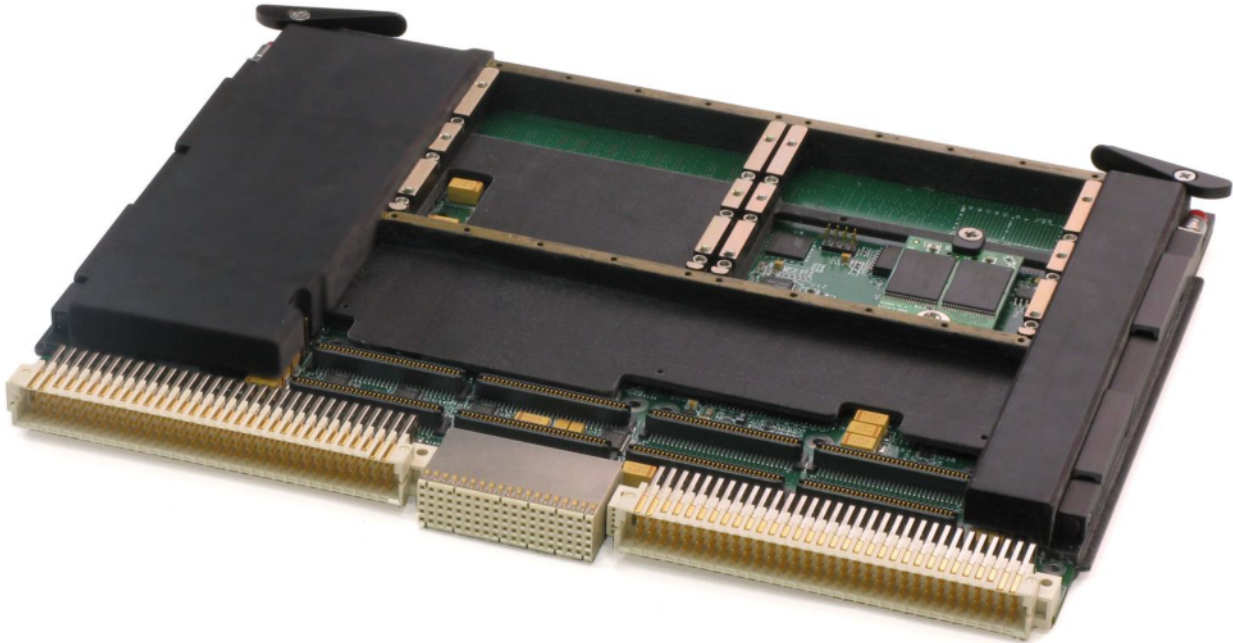

C160

Core™2 Duo VME SBC



- Rugged 6U VME Single-Slot SBC
- Intel® T7500/L7500 Core™2 Duo (Merom) processor @ 2.2 /1.67 GHz
- On-chip 32 kB Data/32 kB Instruction L1 Cache
- On-chip 4 MB L2 Cache
- Up to 2 GB DDR2 SDRAM
- 8 GB IDE Flash Disk
- Up to 16 GB USB SSD (Solid State Disk)
- VME 2eSST with Legacy VME Support
- On-Board Graphics Controller
- Two Gigabit Ethernet Ports
- Two RS-232/422/485 Serial Ports
- Eight Discrete I/O Lines
- Two SATA II Interfaces
- Two USB 2.0 Interfaces
- High Definition Audio
- Two Temperature Sensors
- Real Time Clock with Capacitor and Battery Backup
- Avionics Windowed Watchdog Timer
- Two PMC Slots
- OS Support
 - Windows™
 - Linux®
 - WindRiver VxWorks®
 - Green Hills INTEGRITY®
- Conduction and Air-Cooled Versions
- Vibration and Shock Resistance

Aitech Defense Systems, Inc.

A member of the Aitech Rugged Group
19756 Prairie Street, Chatsworth, CA 91311

Tel: (888) Aitech-8 (248-3248) Fax: (818) 718-9787 e-mail: sales@rugged.com web: www.rugged.com



Functional Description

Processor and Bus Architecture

The C160 is a powerful processing platform achieved using Intel's new Core2 Duo dual-core processor, the GM965 Express Chipset, the ICH8M I/O Controller Hub, and extensive supporting memory arrays. In addition the board's architecture was designed to utilize all bus interfaces to the maximum.

Processor

The Core2 Duo is Intel's high performance, low power processor based on the Intel Core micro-architecture with dual processing cores, 32 kB on-die instruction and data L1 caches, and a 4 MB on-chip L2 cache.

The processor implements Intel's Virtualization Technology. This enables the creation of multiple virtual partitions, each running a different application.

The Core2 Duo provides advanced power management features including Enhanced Intel SpeedStep[®] Technology.

The C160 can be factory configured with the processor operating at 2.2 GHz for the highest performance operation, and at 1.67 GHz for the lowest power operation.

System Architecture

Supporting the Core2 Duo's high performance and to provide a fast data highway for high throughput transfers, the C160 implements Intel's advanced GM965 Express Chipset Graphics Memory Controller Hub (GMCH) and I/O Controller Hub (ICH8M). A 800 MHz Front Side Bus (FSB) ensures high speed communications between the processor and the GMCH, while a Direct Media Interface (DMI) bus provides efficient high-bandwidth communication between the GMCH and ICH8M.

The GMCH provides the host interface controller, system memory interface (SDRAM), direct media interface, external graphics interface, and an integrated graphics engine. The ICH8M integrates a number I/O controllers and interfaces for legacy and high speed devices.

The ICH8M provides an LPC bus as well as multiple high-speed PCIe lanes used to implement VME, PCI-X, and GBE via appropriate bridge devices.

VME

The C160 implements Tundra's Tsi148 PCI-X to VME 2eSST Bridge for interconnection to the VME bus. The VME Bridge is located on the PCI-X bus allowing for high-speed operation and throughput.

The VME interface provides full master and slave capabilities and supports the following:

- 2eSST and 2eVME protocol support
- Legacy traditional VME protocol support
- A64/A32/A24/A16 addressing modes
- MBLT/BLT/D64/D32/D16/D8 data transfer modes
- Interrupter and handler capability on all seven VME interrupt lines
- Four mailbox and four location monitors for in-system board communication
- Full system controller functionality – arbitration, VME clock generation, VME global timeout timer (BERR)
- Flexible register set allowing manipulation of all VME options

The Tsi148 Bridge incorporates large FIFOs for optimal usage of the two buses on which it operates (PCI and VME). In addition, it includes two DMA engines supporting high data rate transfers.

Memory

The C160 is equipped with large memory arrays providing the user with extensive volatile and non-volatile memory resources. These arrays include up to 2 GB fast DDR2 (Double Data Rate) SDRAM operating at 667 MHz, and up to 2 MB of Flash BIOS.

Flash Disk

The C160 features an on-board 8 GB IDE Flash Disk controlled directly from the ICH8 I/O Hub for hosting the OS. The Flash Disk eliminates the need for externally attached mass-storage media.

USB Solid State Disk (SSD)

For convenient file storage, the C160 includes up to 16 GB of USB 2.0 SSD using an SSD module. The integral USB controllers enable high speed data transfers and provide auto wear leveling to ensure maximum longevity of the media.

Integrated Graphics Controller

The C160 includes an on-board graphics controller implemented in the GM965 Express Chipset. The graphics controller is capable of 2D and 3D graphics processing, supporting Microsoft DirectX 10 and SGI OpenGL 1.5/2.0.

The graphics controller also includes a video engine providing hardware motion compensation, 4-channel MPEG YUV, and numerous additional features.

The C160 provides video output interfaces supporting CRT (RGBHV) and TV (composite NTSC/PAL/RS-170).



I/O Interfaces

In addition to its superior processing power, the C160 provides a variety of I/O capabilities.

Ethernet

Two 10BaseT, 100BaseTX and 1000BaseT interfaces are implemented in a Dual Gigabit LAN Controller (with integrated physical layer) using four of the ICH8M PCIe lanes.

Serial I/O

The C160 provides two serial ports supporting full RS-232/422/485 physical interfaces.

USB 2.0 Ports

The C160 includes two USB Rev. 2.0 host controllers (backward compliant with Rev. 1.0 and Rev. 1.1), integrated in the ICH8M device, providing two USB 2.0 ports. Two additional USB 2.0 ports are available at the front panel of air-cooled boards. The controllers integrate the USB transceivers supporting high-speed, full-speed, and low-speed signaling. The C160 is capable of providing power to downstream devices.

Discrete I/O

Up to eight single-ended or four differential general-purpose discrete I/O channels are provided on the C160. Each channel may be independently configured as input or output. Configured as input each of these channels may be programmed to generate an interrupt on any level shift event.

The eight discrete I/O signals are divided into four groups, each controlling two signals. Each group may be configured as two single-ended TTL channels or one differential RS-422 channel.

SATA II

Two SATA II interfaces are provided, to enable connection of an external mass storage device to the C160. The SATA II interfaces are fully compliant with the Serial ATA 1.0 specification with SATA II extensions, supporting data transfer rates of up to 300 MB/s.

HD AUDIO

The ICH8 Controller Hub supports Intel's High Definition (HD) Audio, which is compliant with Microsoft's Universal Audio Architecture (UAA). Using an HD Audio codec, the C160 provides a stereo output interface through its VME connectors.

PMC Expansion

The C160 provides two IEEE 1386-2001 or ANSI/VITA 20-2001 compliant PMC expansion slots for extended flexibility and integration of additional I/O functionality.

The PMC slots reside on fast 64-bit PCI-X bus ports provided by the ICH8M, via two PCIe to PCI-X bridges, and are capable of up to 133 MHz bus operation.

PMC slot 1 is a universal slot that supports both 3.3 V and 5 V PCI I/O signaling levels. This slot therefore does not include a voltage key, enabling the installation of any PMC.

PMC slot 2 supports only 3.3 V PCI I/O signaling levels and thus includes the voltage key that only allows installation of 3.3 V PMCs.

I/O Routing

All onboard and PMC I/O interface signals are available at the C160 P2 and P0 VME connectors.

PMC I/O is per VITA 35.

Air-cooled boards with front panels have the following front panel I/O connectors:

- USB
- CRT
- Gb Ethernet

The two front panel USB interfaces are in addition to the two that are routed to the VME connectors.

Timers

The C160 includes one 32/64-bit and two 32-bit timers/counters providing high-resolution timing functionality as well as chaining for long interval counting applications.

A real-time clock (RTC) provides time and date keeping. The RTC is backed up by a large capacitor and battery for long-term parameter storage.

A watchdog timer is also available on the C160. Implemented in the system FPGA, the watchdog is an avionics style programmable windowed watchdog timer, which must be serviced within a software programmable window defined by minimum and maximum times. If serviced too early, too late, or not at all, this watchdog timer will generate a timeout event. It may be independently set to generate a non-maskable interrupt or reset the SBC.

Software

Test and Diagnostic Features

The C160 is supplied with a customized BIOS tailored to fit the C160 architecture, capabilities and features.

The BIOS includes POST capabilities as well as system configuration options for boot device, boot sequence, etc.

A JTAG/COP interface to the processor is provided for debugging and development purposes.



Operating Systems

The C160 and its BIOS fully support installation and operation of the following operating systems:

- Microsoft Windows XP
- Linux
- WindRiver VxWorks
- Green Hills INTEGRITY

Operating system specific device drivers are provided for all on-board resources, allowing the user to take full advantage of the C160's powerful features.

Support for other operating systems may be available upon request.

Mechanical Features

The C160 is available in two mechanical formats:

- Air-cooled per ANSI/VITA 1-1994
- Conduction-cooled per IEEE 1101.2

Both mechanical formats are single slot 6U modules.

Custom metal frame provides excellent rigidity and shock resistance. In addition, a custom metal frame provides an array of stiffeners to support rugged PMC boards.

Dimensions

- Air-cooled: per ANSI/VITA 1-1994
- Conduction-cooled: per IEEE 1101.2

Weight

- Air-cooled: < 800 g (1.75 lbs)
- Conduction-cooled: < 900 g (2.0 lbs)

Thermal Management

Careful mechanical design, including custom heatsink modules combined with a metal frame, allow for optimal heat dissipation and relief of the board. The C160 is also equipped with two temperature sensors, located at temperature-critical locations, to monitor board temperature and provide temperature data to user application software.

Power Requirements

The C160 takes all its power from the VME64x backplane. It should be provided with +5.0V, +3.3V and $\pm 12V$ as defined by the VME64x specification ($\pm 12V$ is required for PMC compliance only, the C160 does not require $\pm 12V$ for its own operation).

All other power sources required by C160 resources are generated on board.

Fully featured (no PMC installed), typical C160 power consumption (processor @ 1.67 GHz) is approximately 25 W, as follows:

+3.3 V ($\pm 5\%$)	0 A (no PMCs mounted, internal 3.3 V power supply)
+5.0 V ($\pm 5\%$)	5 A (nominal)
+12 V ($\pm 10\%$)	0 A (no PMCs mounted)
-12 V ($\pm 10\%$)	0 A (no PMCs mounted)

Environmental Features

Please refer to the Aitech Ruggedization datasheet.



C160 Core™2 Duo VME SBC

Ordering Information for the C160

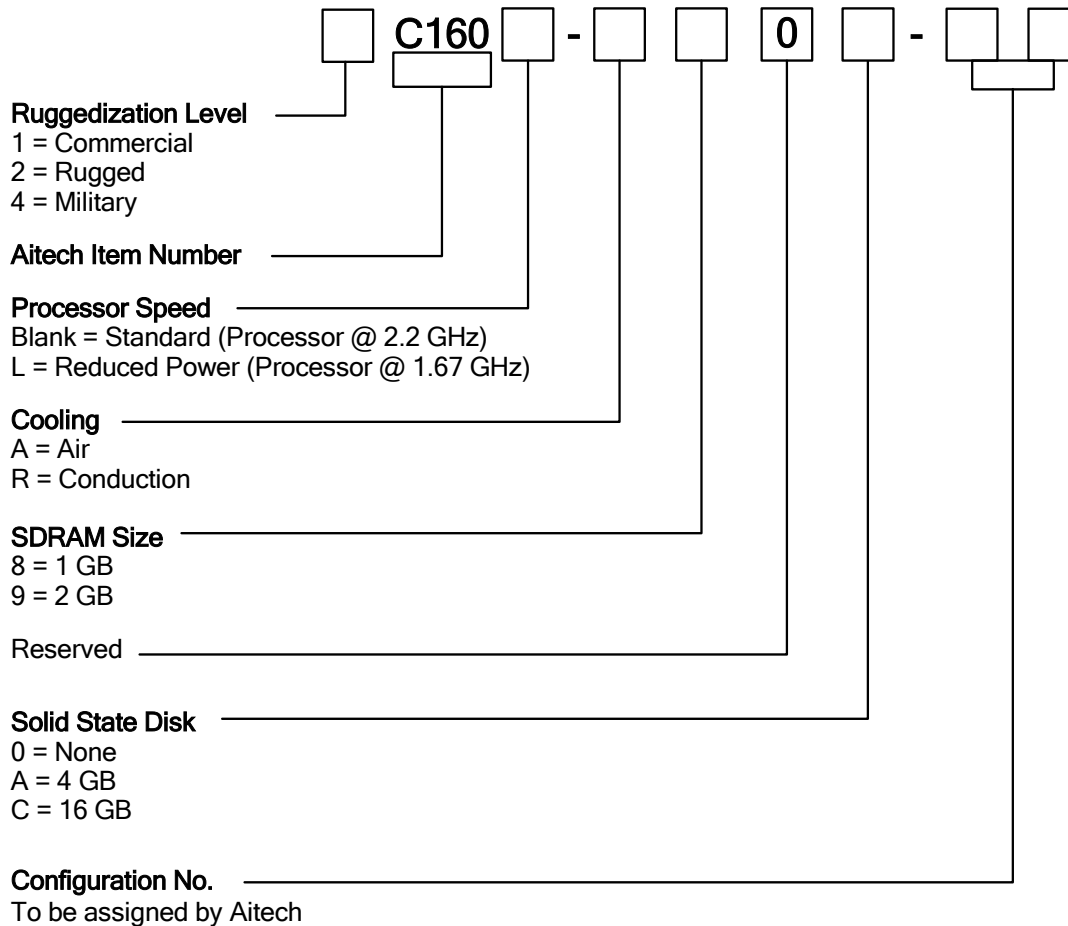

Example: 4C160L-R90A-00

For more information about the C160 or any Aitech product, please contact Aitech Defense Systems sales department at (888) Aitech-8 (248-3248).



www.dpie.com

Diamond Point International (Europe) Ltd

Suite 13, Ashford House, Beaufort Court

Sir Thomas Longley Road, Rochester, Kent, ME2 4FA, UK

Phone 01634 300900 - Fax 01634 722398 - Email sales@dpie.com – Web www.dpie.com

All names, products, and/or services mentioned are trademarks or registered trademarks of their respective holders. All information contained herein is subject to change without notice.

C160T0109R15

Aitech Defense Systems, Inc.

A member of the Aitech Rugged Group

19756 Prairie Street, Chatsworth, CA 91311

Tel: (888) Aitech-8 (248-3248) Fax: (818) 718-9787 e-mail: sales@rugged.com web: www.rugged.com