



M457

Telemetry PCM, Serial and Discrete I/O PMC



- Telemetry PCM, High Speed Serial and Discrete I/O Communication PMC
- High Performance MPC8260 PowerQUICC II™ Communication Controller
- PowerSpan II™ PCI to PowerPC Bridge
- IRIG 106 Standard PCM Data Structure at Data Rate of up to 5Mbps
- PCM and Communication Parameters are Fully Software Programmable
- RS-422/TTL Digital Outputs Transmitting Raw PCM Data Stream and Clock
- Up to Six RS-422/485 or RS-232 High Speed Serial Sync/Async Channels Independently Programmable (Two when PCM is used)
- Serial Channels Support Sync/Async Data Rates of up to 10 Mbps/2 Mbps
- Up to 16 Independently Programmable Differential RS-422 Discrete I/O Channels (16 with Interrupt Capability)
- 64MB SDRAM for Data Buffering
- PCI 2.2 Interface Compliant, 64-bit @ 66 MHz PCI Bus Interface
- All I/O Channels are Routed to the PMC I/O Connector. High Speed Serial Channels May Be Routed to Front Panel (Air Cooled Version)
- Multiple DMA Engines Optimized for Minimum Traffic on the Carrier Board PCI Bus
- IEEE 1386-2001 (Air Cooled) or VITA 20-2001 (Conduction Cooled) Compliant
- Commercial/Military Level Ruggedization
- Drivers for VxWorks®
- BIT (Built-in-Test) Available for Complete Functional Testability

Aitech Defense Systems, Inc.

A member of the Ai-Rugged Group

9301 Oakdale Ave, Chatsworth, Ca 91311

Tel: (888) Aitech-8 (248-3248) Fax: (818) 718-9787 e-mail: sales@rugged.com web: www.rugged.com



PCM Telemetry and High Speed I/O PMC

The M457 is a general-purpose communication PMC, supporting Pulse Code Modulation (PCM) telemetry, high-speed serial communication (Synchronous/Asynchronous) and discrete I/O.

The M457 I/O capabilities include one PCM engine, up to 6 high-speed serial channels and up to 16 discrete I/O channels.

The PCM engine is capable of telemetry data stream transmission in a predefined format. These transmission formats includes NRZ, RNRZ, RZ, BIΦ and DM).

The M457 PMC serial channels are independent high-speed synchronous/asynchronous channels supporting bit rates of up to 10Mbps (2Mbps in ASYNC mode).

Data transferred over the PCI bus to/from the carrier board system memory is performed using high performance DMA engines integrated in the PowerQuicc II controller.

The M457 PMC operates independently and requires only minimal intervention by the host, thus maximizing host performance.

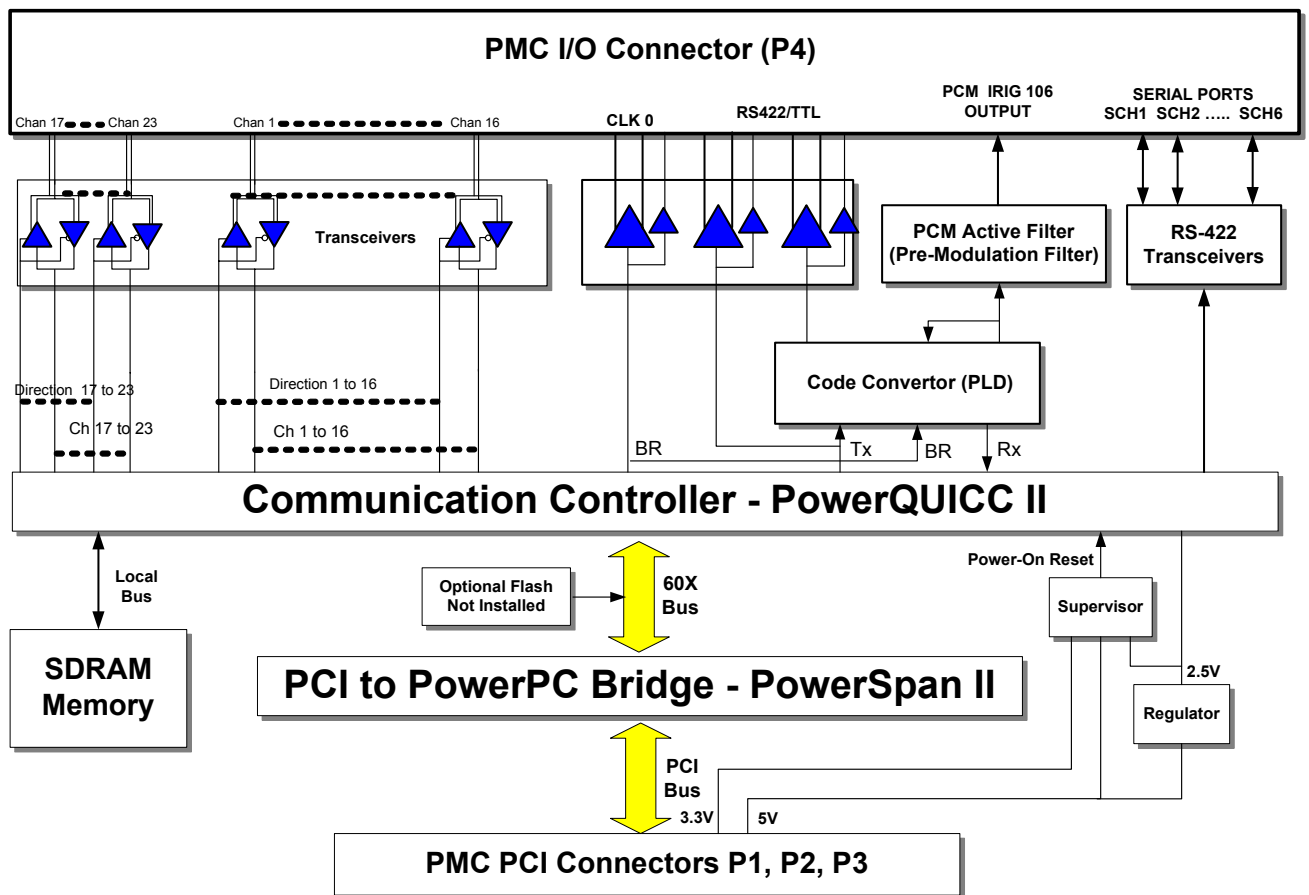

M457 Block Diagram



Features

Architecture

The M457 architecture implements the powerful MPC8260 PowerQUICC II™ communication controller for the PCM telemetry data stream generation, discrete and the serial channels.

Configured in slave mode the PowerQUICC II™ interfaces the carrier board's PCI bus interface through the PowerSpan II™ PCI to PowerPC Bridge device.

The PowerSpan II™ is a two-port device (PCI at one end and PowerPC™ 60x bus at the other end).

The M457 PMC incorporates several DMA engines to allow high data throughput over the PCI bus between the carrier board system memory and M457 local memory.

Onboard 64MB SDRAM is available for buffering received and transmitted data to/from the carrier board.

PCI Bus Interface

The M457 incorporates a high performance Tundra PowerSpan II PCI to 60x bus Bridge supporting 64-bit PCI bus operation at 66MHz and is fully compliant with the PCI Rev. 2.2 specification.

The PMC is a universal PMC supporting both +5V and +3.3V PCI signaling levels. It does not utilize the PCI V_{I/O} power supply.

PCM Interface

The PCM engine is implemented using three of the six PowerQUICC II™ high-speed serial ports. These ports are configured in transparent mode and joined together for time division multiplexing (TDM) in order to construct the PCM stream. PCM data is loaded into the 3 serial port buffers and transmitted in a serial NRZ coded data stream at a programmable bit rate of up to 5Mbps (default is 2.5Mbps). To allow maximum flexibility in constructing the PCM stream, all PCM parameters such as block size, frame size, and sync data type and size are software programmable.

When no data is available for transmission filler pattern is transmitted.

The PowerQUICC II™ NRZ coded data stream conversion to standard telemetry stream (IRIG 106 standard output compatible) is facilitated using a programmable CPLD logic.

NRZ data stream from the PowerQUICC IITM port is converted by the CPLD to one of five coding formats (NRZ, RNRZ, RZ, BIΦ and DM). Selection is made by software.

A six-pole active LP filter is used to produce the PCM analog output (50Ω impedance). The -3dB point of the filter is factory adjustable (default is 1.9MHz).

In addition to the PCM analog output, three differential RS-422/TTL outputs are available. The outputs are NRZ, CLK and the PCM coded output (NRZ, RNRZ, RZ, BIΦ and DM).

PCM output signals are routed to the PMC I/O connector.

Serial Communication Interface

The general-purpose independent Synchronous/Asynchronous channels are implemented using up to six of the PowerQUICC II™ FCC/SCC/SMC units. These units allow high flexibility in channel configuration and operation. Note that when the PCM engine is utilized only three general-purpose serial channels are available.

All Channels support bit rates of up to 10Mbps in Sync modes and 2Mbps in Async mode (bit rate is programmable). All serial channels employ SDMA engines for high data throughput over the PCI and 60x buses.

All serial channels support both differential RS-422/485 and RS-232 interfaces. All I/O signals are routed to the PMC I/O connector (optional routing to front panel is available in the air-cooled version).

M457 Discrete and Clock

The M457 includes 23 discrete channels specially designed to provide the user with maximum flexibility for applications requiring multiple discrete I/O ports. The 23 channels comprise of 16 channels with interrupt capabilities and 7 channels without interrupt capabilities.



All discrete I/O ports are individually (or commonly) software programmable to operate as inputs or outputs. This allows high flexibility and ease of use in the I/O channel configuration.

All Discrete I/O channels physical levels are RS-422 compliant.

The discrete I/O RS-422 differential drivers/receivers are short protected high drive high reliability devices.

Discrete I/O ports 1-16, when configured as inputs, are capable of interrupt generation at input level transition. This interrupt may be routed to the carrier board over the PCI bus.

All discrete I/O channels are routed to the PMC I/O connector

Software

Test and Diagnostics Features

- Full Functional testability using internal/external loop-backs
- BIT software provided for loading on the host processor platform

Software Drivers

The M457 PMC is delivered with a complete set of VxWorks® drivers and BIT for all the PMCs modules – PCM engine, serial ports and discrete I/O channels.

Ruggedization

- Series 100, commercial/development
- Series 200, rugged
- Series 400, military

Mechanical Features

The M457 PMC is available in two mechanical formats:

- Air-cooled per IEEE 1386-2001 for installation on top commercial and rugged air-cooled carrier boards.
- Conduction cooled per ANSI/VITA20-2001 for installation on top IEEE 1101.2 conduction-cooled carrier boards.

High power components are cooled by an aluminum heatsink.

Dimensions

- Air-cooled: per IEEE 1386-2001
- Conduction cooled: per ANSI/VITA 20-2001

Power Requirements

The M457 draws most of its power from the +3.3V power supply. It has its on-board power circuits for other power levels required by its components.

Total power consumption (maximum): 4.5W

+5.0V (± 5%)	0.35A (typ)	0.4A (max)
+3.3V (± 5%)	0.5A (typ)	0.7A (max)
+12V (± 10%)	0A	
-12V (± 10%)	0.1A (typ)	0.1A (max)

Environmental Features

Please, refer to the Aitech ruggedization datasheet.



Ordering Information for the M457

M457 - -

Ruggedization Level

1 = Commercial
2 = Rugged
4 = Military

Aitech Item Number _____

Cooling _____

A = Air Cooled
R = Conduction

I/O Options	1	2
1 = Serial & Discrete		
2 = Telemetry, Serial & Discrete		
Telemetry		
Analog PMC out	-	1
TTL PCM Clock out	-	1
TTL NRZ	-	1
TTL RNRZ ⁽¹⁾	-	1
Diff PCM Clock	-	1
Diff RNRZ ⁽¹⁾	-	1
Diff NRZ	-	1
Serial ⁽²⁾		
Tx, Rx (RS-232, 422, 485)	6	2
T _{clk} , R _{clk} (RS-232, 422, 484)	6	2
Diff Discrete I/O with interrupts	8	12
Diff Discrete I/O without interrupts	-	4

Notes: (1) Other PCM coding types are available (contact sales department).
(2) If a serial port is configured for asynchronous mode (no clock is needed), the clock channels may be used for discrete I/O.

Configuration No. _____

To be assigned by Aitech
Example: 1M457-A1-00



www.dpie.com

Diamond Point International (Europe) Ltd

Suite 13, Ashford House, Beaufort Court
Sir Thomas Longley Road, Rochester, Kent, ME2 4FA, UK
Phone 01634 300900 - Fax 01634 722398 - Email sales@dpie.com – Web www.dpie.com

Names, products, and/or services mentioned are trademarks or registered trademarks of their respective holders. All information contained herein is subject to change without notice.