

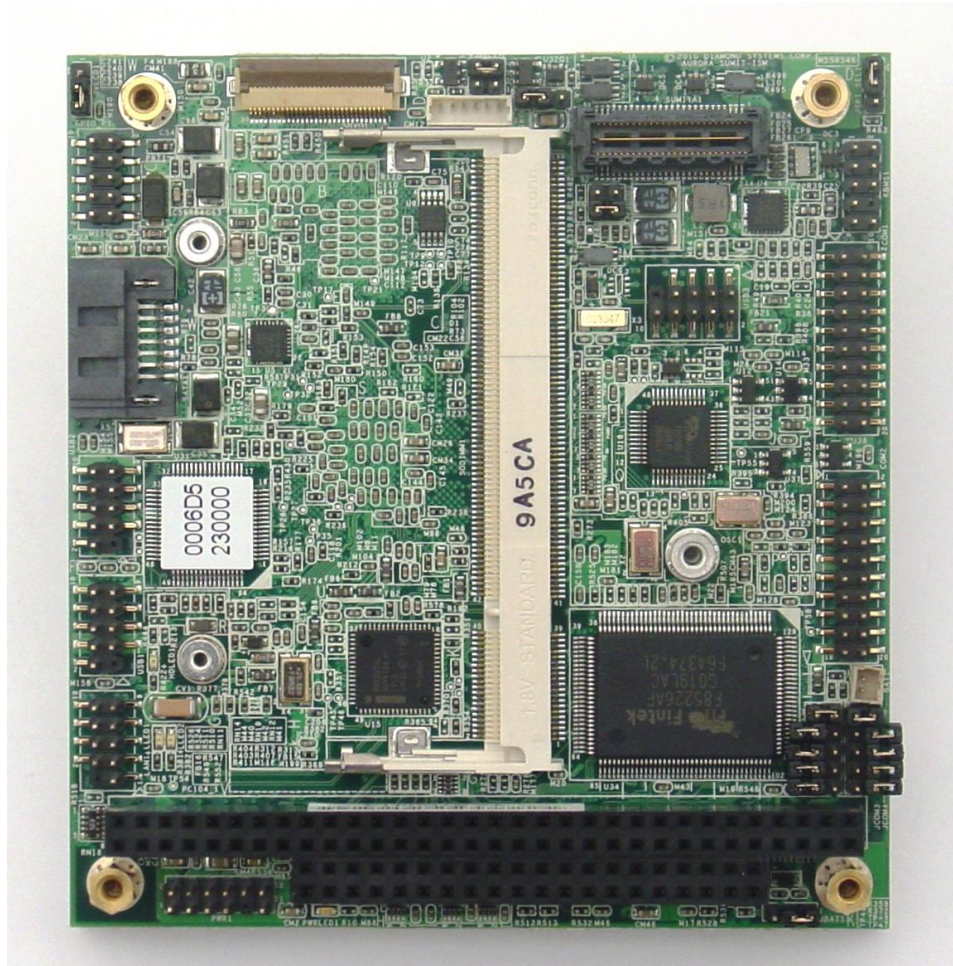

DIAMOND SYSTEMS CORPORATION

AURORA

SUMIT-ISM Single Board Computer with Atom Z530 CPU



Revision	Date	Comment
0.9	10/25/10	Final review version
0.91	10/26/10	Ruggedized SDRAM added
0.92	11/10/10	SDVO connector pin out updated and other minor updates

**FOR TECHNICAL SUPPORT
PLEASE CONTACT:**

support@diamondsystems.com

© Copyright 2010
Diamond Systems Corporation
1255 Terra Bella Ave.
Mountain View, CA 94043 USA
Tel 1-650-810-2500
Fax 1-650-810-2525
www.diamondsystems.com

CONTENTS

Important Safe-Handling Information	4
1. Introduction	5
1.1 Aurora SBC Features	6
1.2 SUMIT Socket Resources	7
1.3 Software Compatibility	7
1.4 Thermal Considerations	7
2. Functional Overview	8
2.1 Block Diagram	8
2.2 Aurora Dimensions	9
2.3 Connector Locations	10
2.3.1 Connector Summary	11
2.4 Configuration Jumpers	12
2.4.1 Configuration Jumper Summary	13
3. Getting Started	13
3.1 Introducing the Aurora Development Kit	14
3.1.1 Aurora Cable Kit	15
3.2 System Setup	16
3.2.1 Keyboard and Mouse	16
3.2.2 USB Flashdisk Socket	16
3.2.3 Mass Storage Devices	16
3.2.4 Connecting Power	16
3.2.5 Display	16
3.2.6 Installing Aurora in an Enclosure (optional)	16
3.3 Booting the System	17
3.3.1 BIOS Setup	17
3.3.2 Operating System Drivers	17
4. Interface Connector Details	18
4.1 SDVO Connector (SDVO1)	18
4.2 LCD Panel (LVDS Interface) Connector (LVDS1)	19
4.3 LCD Backlight Connector (INV1)	19
4.4 SUMIT-A Expansion Bus (SUMITA1)	20
4.5 Serial Ports (COM1, COM2)	21
4.6 PS/2 Keyboard/Mouse (KBMS1)	22
4.7 External Battery (BAT1)	22
4.8 PC/104 (ISA) Expansion Bus (PC104_1)	23
4.9 Input Power (PWR1)	24
4.10 Ethernet (LAN1)	24
4.11 USB 0-1 (USB1)	25
4.12 USB 2-3 (USB2)	25
4.13 USB Flashdisk (USB3)	26
4.14 SO-DIMM DRAM (SODIMM1)	26
4.15 SATA (SATA1)	26
4.16 GPIO (GPIO_P1)	27
5. Configuration Jumper Details	27
5.1 LCD Panel Power Select - 3.3V/5V (JVLCD1)	27
5.2 LCD Backlight Brightness Control (JBKC1)	28
5.3 LCD Backlight Power (JINV1)	28
5.4 LCD Scan Direction (JLCD1)	28
5.5 Internal or External SPI Flash (JSP1 SEL1)	28
5.6 CMOS RAM Reset / On-board Backup Battery Disconnect (JBAT1)	29
5.7 Serial Ports (JCOM3, JCOM4)	29
6. BIOS	30
6.1 Entering the BIOS	30
6.2 Restoring Default BIOS Settings	30
6.3 Setting the Date and Time	30
6.4 ISA Bus IRQ Reservation	30
6.5 Boot Priority	30
6.6 Chipset	30
6.7 Super I/O Configuration	31
6.8 Console Redirection	31

7. Digital I/O Lines	32
7.1 DIO Registers	32
7.2 DIO Programming.....	32
8. Watchdog Timer	35
8.1 Registers.....	35
8.2 Programming Sample Code	36
9. FlashDisk Modules	37
9.1 Overview.....	37
9.2 Models and Capacities	37
9.3 Features.....	37
9.4 Flashdisk Installation	38
10. Ruggedized So-DIMM Modules	38
10.1 Models and Capacities	38
10.2 SO-DIMM Memory Installation	38
11. Panel I/O Board	39
11.1 Mechanical Drawing	40
11.2 Outside Facing I/O Connectors	41
11.2.1 Input Power (J1).....	41
11.2.2 Ethernet (J23 Ethernet).....	41
11.2.3 VGA (VGA)	41
11.2.4 USB (USB1, USB2, USB3, USB4)	41
11.2.5 PS/2 Keyboard and Mouse (J25 Keyboard, J26 Mouse)	41
11.2.6 Serial Ports (COM1, COM2, COM3, COM4)	41
11.3 Power Routing	42
12. Thermal Pad	44
13. Specificatlons	44

IMPORTANT SAFE-HANDLING INFORMATION



WARNING: ESD-Sensitive Electronic Equipment!

Observe ESD-safe handling procedures when working with this product.

Always use this product in a properly grounded work area and wear appropriate ESD-preventive clothing and/or accessories.

Always store this product in ESD-protective packaging when not in use.

Safe Handling Precautions

Aurora contains numerous I/O connectors that connect to sensitive electronic components. This creates many opportunities for accidental damage during handling, installation and connection to other equipment. The list here describes common causes of failure found on boards returned to Diamond Systems for repair. This information is provided as a source of advice to help you prevent damaging your Diamond (or any vendor's) embedded computer boards.

ESD damage – This type of damage is almost impossible to detect, because there is no visual sign of failure or damage. The symptom is that the board simply stops working, because some component becomes defective. Usually the failure can be identified and the chip can be replaced.

To prevent ESD damage, always follow proper ESD-prevention practices when handling computer boards.

Damage during handling or storage – On some boards we have noticed physical damage from mishandling. A common observation is that a screwdriver slipped while installing the board, causing a gouge in the PCB surface and cutting signal traces or damaging components.

Another common observation is damaged board corners, indicating the board was dropped. This may or may not cause damage to the circuitry, depending on what is near the corner. Most of our boards are designed with at least 25 mils clearance between the board edge and any component pad, and ground / power planes are at least 20 mils from the edge to avoid possible shorting from this type of damage. However these design rules are not sufficient to prevent damage in all situations.

A third cause of failure is when a metal screwdriver tip slips, or a screw drops onto the board while it is powered on, causing a short between a power pin and a signal pin on a component. This can cause overvoltage / power supply problems described below. To avoid this type of failure, only perform assembly operations when the system is powered off.

Sometimes boards are stored in racks with slots that grip the edge of the board. This is a common practice for board manufacturers. However our boards are generally very dense, and if the board has components very close to the board edge, they can be damaged or even knocked off the board when the board tilts back in the rack. Diamond recommends that all our boards be stored only in individual ESD-safe packaging. If multiple boards are stored together, they should be contained in bins with dividers between boards. Do not pile boards on top of each other or cram too many boards into a small location. This can cause damage to connector pins or fragile components.

Power supply wired backwards – Our power supplies and boards are not designed to withstand a reverse power supply connection. This will destroy each IC that is connected to the power supply. In this case the board will most likely will be unrepairable and must be replaced. A chip destroyed by reverse power or by excessive power will often have a visible hole on the top or show some deformation on the top surface due to vaporization inside the package. **Check twice before applying power!**

Bent connector pins – This type of problem is often only a cosmetic issue and is easily fixed by bending the pins back to their proper shape one at a time with needle-nose pliers. This situation can occur when pulling a ribbon cable off of a pin header. Note: If the pins are bent too severely, bending them back can cause them to weaken unacceptably or even break, and the connector must be replaced.

1. INTRODUCTION

Aurora is a high performance, highly integrated single board computer in the PC/104-sized, SUMIT-ISM form-factor incorporating a wealth of standard PC-style I/O plus on-board digital I/O. It accepts both SUMIT-A and PC/104 (ISA) add-on I/O modules. An integrated, bottom-mounted heatspreader dissipates heat efficiently to the system enclosure. This configuration leaves the SBC's top side free for easy access to memory, on-board I/O, and expansion sockets.

Key feature highlights include:

- Compact, low-power, high-performance, stackable SBC
- Intel Atom Z530 CPU at 1.6GHz
- Up to 2GB ruggedized SO-DIMM DDR2 SDRAM
- Comprehensive set of I/O interfaces
- Optional on-board USB flashdisk
- PC/104-sized SUMIT-ISM form-factor
- PC/104 (ISA) and SUMIT-A (PCIe) stackable expansion
- -20°C to +71°C (-2°F to +160°F) operating temperature

Aurora's features are summarized on the next page.



Figure 1: Edge View of the Aurora SBC

<i>Aurora Models</i>	<i>Processor Type</i>	<i>Processor Clock</i>	<i>SO-DIMM RAM</i>
AUR-Z530-16-0G	Intel Atom Z530P	1.6GHz	0GB SDRAM
AUR-Z530-16-1G	Intel Atom Z530P	1.6GHz	1GB SDRAM
AUR-Z530-16-2G	Intel Atom Z530P	1.6GHz	2GB SDRAM

1.1 Aurora SBC Features

Aurora is a rugged, single board computer (SBC) based on the 1.6GHz Intel Atom Z530P CPU and conforming to the compact, PC/104-sized, SUMIT-ISM form-factor (90 x 96mm, www.sff-sig.org). It provides multiple expansion options by means of PC/104 (ISA) modules and SUMIT-A modules.

Functions

- Processor: Intel Atom Z530P at 1.6GHz
- Cooling: Heatspreader, fanless
- Memory: Up to 2GB ruggedized SO-DIMM DDR2 DRAM
- Display options:
 - LVDS flat panel interface
Diamond supports Sharp LQ121S1LG41 and LQ121S1LG42 flat panels
 - SDVO (optional VGA adapter accessory available)
- LVDS backlight power: +5V or +12V jumper selectable
- USB ports: 4 USB 2.0
- Serial ports: 2 RS-232/422/485, 2 RS-232
- Networking: 1 Gigabit Ethernet – Intel 82754
- Mass storage:
 - 1 SATA port
 - Support for up to 8GB USB flashdisk
- Keyboard/Mouse: PS/2 with BIOS support for USB
- Digital I/O: 8 digital I/O lines
- Watchdog Timer: Yes
- PCI Express: 1 PCIe x1 lane to SUMIT-A bus
- Expansion buses:
 - SUMIT-A stackable
 - PC/104 (ISA) stackable
- Input power: 5V \pm 5%
- Power consumption: 5.4W
- Operating temp.: -20°C to +71°C (-2°F to +160°F)
- Dimensions: 3.55" x 3.775" x 0.9" (90mm x 96mm x 23mm)
- Weight: 7.5oz / 212g
- RoHS Compliant

Operating System Support

- Linux 2.6
- Windows XP and XPe

1.2 SUMIT Socket Resources

Aurora's SUMIT-A expansion socket provides the host interface resource support indicated in the table below. For further details on the SUMIT expansion standard, visit SFF-SIG.org/sumit.html.

SUMIT Resources		
Company:	Diamond Systems Corp.	
Product:	Aurora SBC	
Form-factor:	PC/104	
	SUMIT A	SUMIT B
PCIe x1	1	
PCIe x4		
USB	3	
ExpressCard	–	
LPC	√	
SPI /uWire	–	
SMBus/ I2C	SMBus	
+12V	√	
+5V	√	
+5Vsb	–	
+3.3V	√	
Notes: www.sff-sig.org/sumitlabel.html		

1.3 Software Compatibility

Aurora is compatible with Linux, Windows XP, and Windows Embedded Standard. All necessary drivers for these operating systems are provided with the product.

1.4 Thermal Considerations

All models of Aurora are specified for a -20°C to +71°C operating range. Diamond provides a heatspreader attached to the Aurora single board computer as a conductive cooled thermal layer. However, this heatspreader by itself does not constitute the complete thermal solution necessary for any specific implementation, but provides a common interface between the single board computer and the customer's implementation-specific thermal solution.

The outside surface of the Aurora heatspreader must be kept at a temperature not to exceed +85°C. If your environment exceeds this temperature, you are responsible for removing the additional heat from the system through either an additional passive thermal solution or fan solution.

2. FUNCTIONAL OVERVIEW

2.1 Block Diagram

Figure 2 shows Aurora's functional blocks.

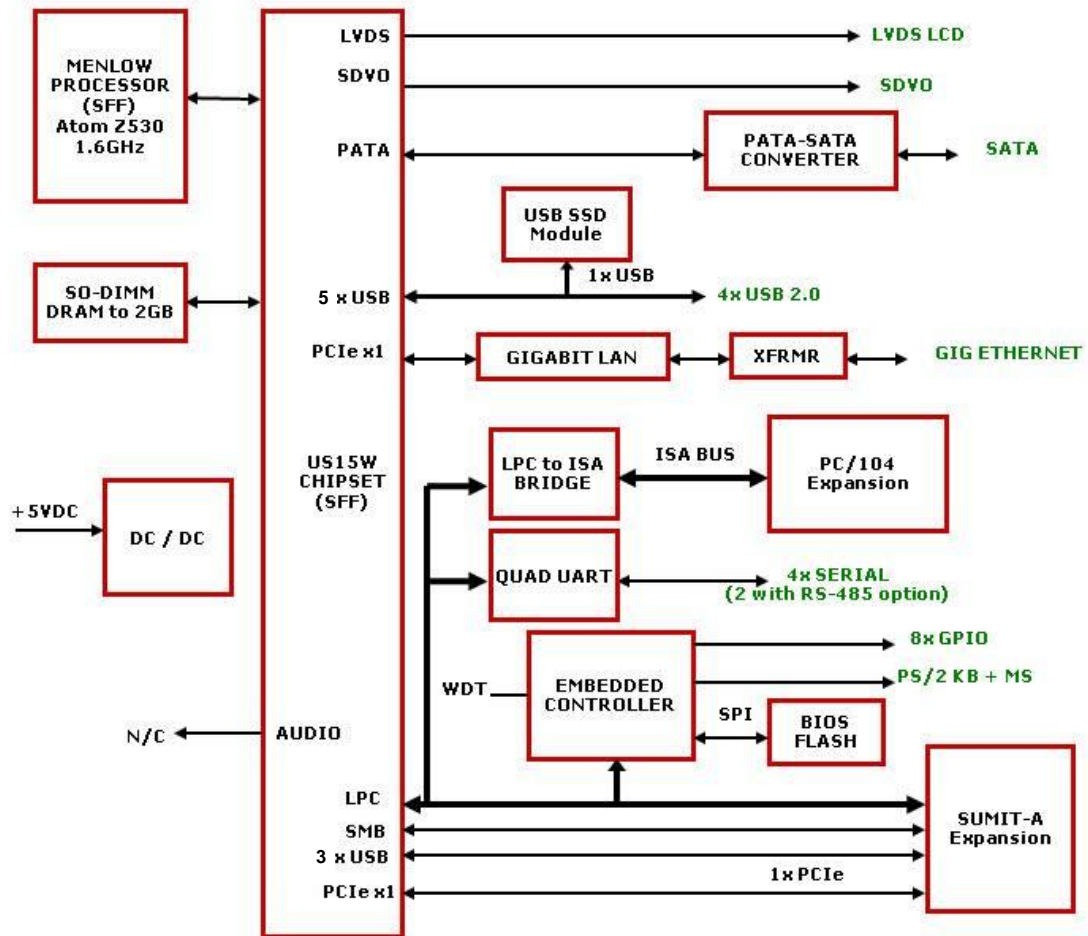

Figure 2: Aurora Functional Block Diagram

2.2 Aurora Dimensions

Figure 3 shows the overall dimensions of the Aurora SBC.

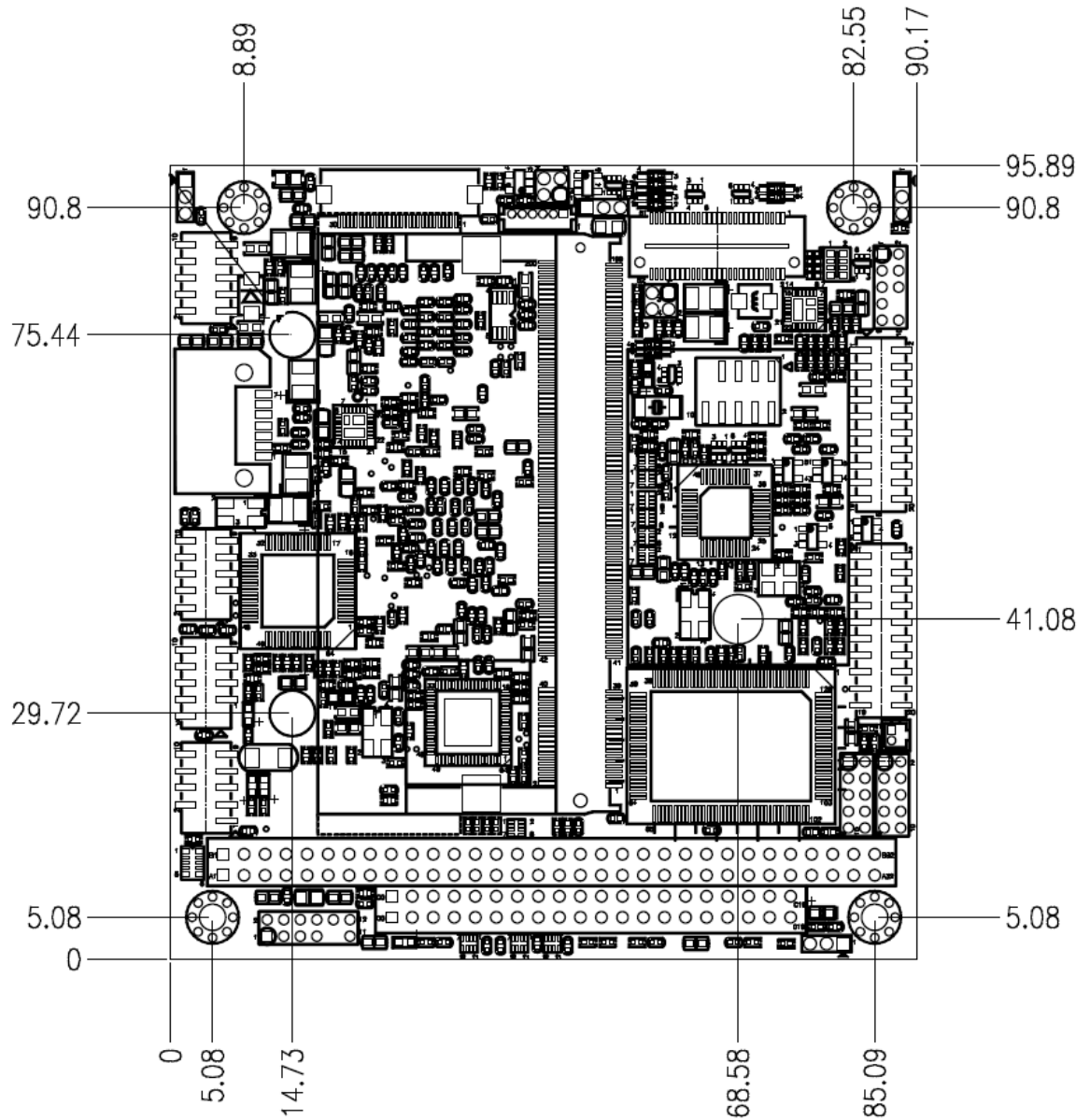

Figure 3: Aurora Dimensions

2.3 Connector Locations

Figure 4 illustrates the position of interface and bus connectors jumpers located on the top side of the Aurora SBC. Two expansion buses – PC/104 (ISA) and SUMIT-A (PCIe, etc.) – enable on-board stacking of additional I/O boards. The connectors for both expansion buses are located on the top side of the board.

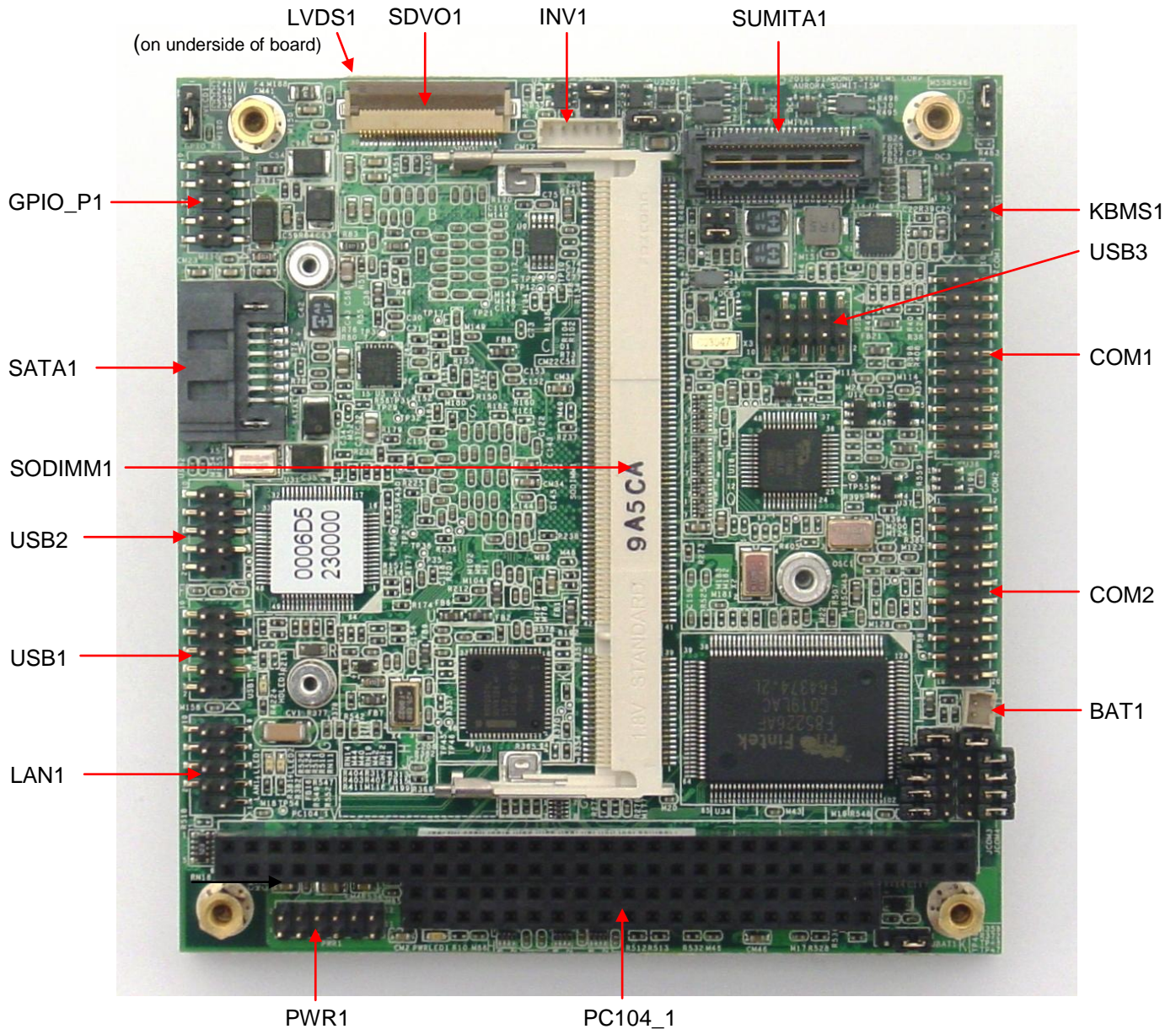

Figure 4: Aurora SBC Connector Locations

2.3.1 Connector Summary

The following table summarizes the functions of Aurora's interface, utility, and power connectors. Signal functions relating to all of Aurora's interface connectors are discussed in greater detail in Section 4 of this document. Diamond offers an optional Aurora Cable Kit (number C-AUR-KIT), which provides mating cable assemblies for most of Aurora's I/O interface connectors.

Connector Function	Silkscreen Label	Connector Type
Serial Digital Video Out	SDVO1	30-pin right-angle flat connector
LCD Backlight	INV1	6-pin header
SUMIT-A Bus	SUMITA1	52-pin female socket
PS/2 Keyboard Mouse	KBMS1	10-pin dual-row header
On-board USB flashdisk	USB3	10-pin dual-row header
Serial Ports	COM1, COM2	20-pin dual-row header
External Battery Input	BAT1	2-pin plug
PC/104 Expansion Bus	PC104_1	104-pin quad-row socket
Input Power	PWR1	12-pin dual-row header
Ethernet	LAN1	10-pin dual-row header
USB Ports	USB1, USB2	10-pin dual-row header
SO-DIMM DRAM	SODIMM1	SO-DIMM memory socket
SATA	SATA1	7-pin standard SATA interface
GPIO	GPIO_P1	10-pin dual-row header
LCD (LVDS) Panel	LVDS1	20-pin single-row header

2.4 Configuration Jumpers

Figure 5 shows the configuration jumper groups that are located on the topside of the Aurora SBC. Refer to Section 5 for details on the functions and configuration options associated with each jumper group.

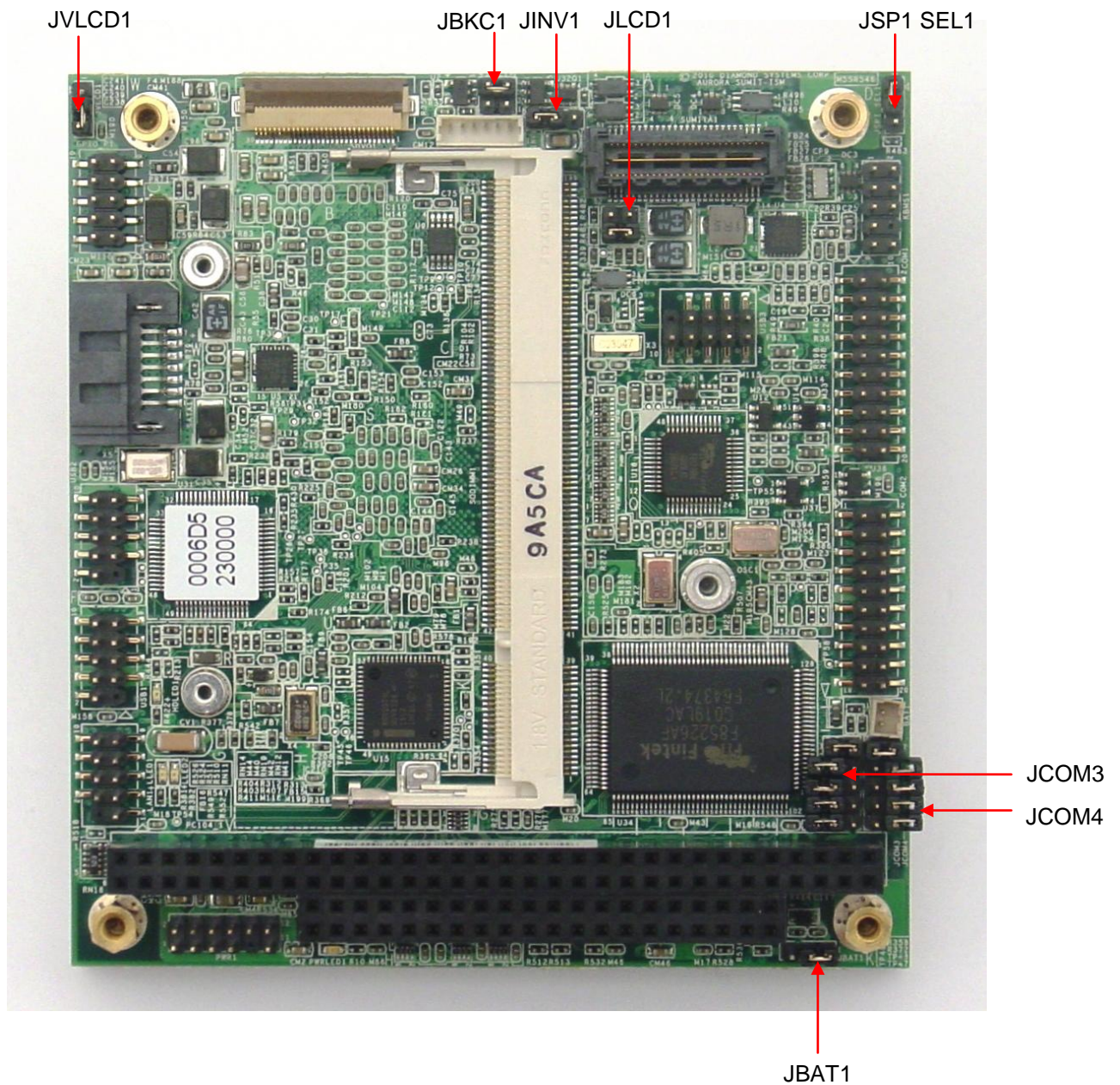

Figure 5: Aurora SBC Configuration Jumper Groups

2.4.1 Configuration Jumper Summary

Aurora's configuration jumpers are listed below. Refer to Section 5 of this document for details regarding the configuration of these jumper groups.

Jumper Group Function	Silkscreen Label	Array Size
LCD Panel Power Select (3.3V/5V)	JVLCD1	1 x 3
LCD Backlight Brightness Control	JBKC1	2 x 2
LCD Backlight Power (5V/12V)	JINV1	1 x 3
LCD Scan Direction	JLCD1	2 x 2
Internal or External SPI Flash	JSP1 SEL1	1 x 3
Serial Ports 3 and 4 RS-422/485 configuration	JCOM3, JCOM4	2 x 5
CMOS RAM Reset / On-Board Backup Battery Disconnect	JBAT1	1 x 3

3. GETTING STARTED

First-time Aurora users normally receive the product as part of Diamond's Aurora Development Kit, which provides everything needed to ensure rapid application development. This section of the Aurora User Manual covers basic hardware setup, power connection, system boot-up, and initial software configuration. After Aurora is up and running, refer to the later sections of this manual for the detailed hardware and software reference information needed to adapt the product to specific applications.

Important Safe-Handling Information



WARNING: ESD-Sensitive Electronic Equipment!

Observe ESD-safe handling procedures when working with this product.

Always use this product in a properly grounded work area and wear appropriate ESD-preventive clothing and/or accessories.

Always store this product in ESD-protective packaging when not in use.

Please refer to page 4 of this manual ("Important Safe-Handling Information") for further details.

3.1 Introducing the Aurora Development Kit

The Aurora Development Kit (DK-AUR-01) provides everything required for Aurora-based rapid application development. The table below lists the boards, cables, and other items included.

<i>Item</i>	<i>Diamond P/N</i>	<i>Description</i>
1	AUR-Z530-16-1G	Aurora PC/104 SBC, 1.6GHz Atom Z530, 1GB SDRAM
2	ACC-VGA-03	VGA Accessory Kit for Aurora
3	8890300	4GB USB flashdisk with Linux pre-loaded
4	PS-5V-04	AC Power Adapter, +5VDC
5	7460610	Quickstart Guide for Aurora SBC
6	C-AUR-KIT	Aurora Cable Kit for on-board I/O
7	DOC-PKG	Documentation Package

3.1.1 Aurora Cable Kit

The Aurora Cable Kit (number C-AUR-KIT) provides convenient access to most of Aurora's I/O features. The kit's cable assemblies are shown in the photo below, and identified in the table that follows.

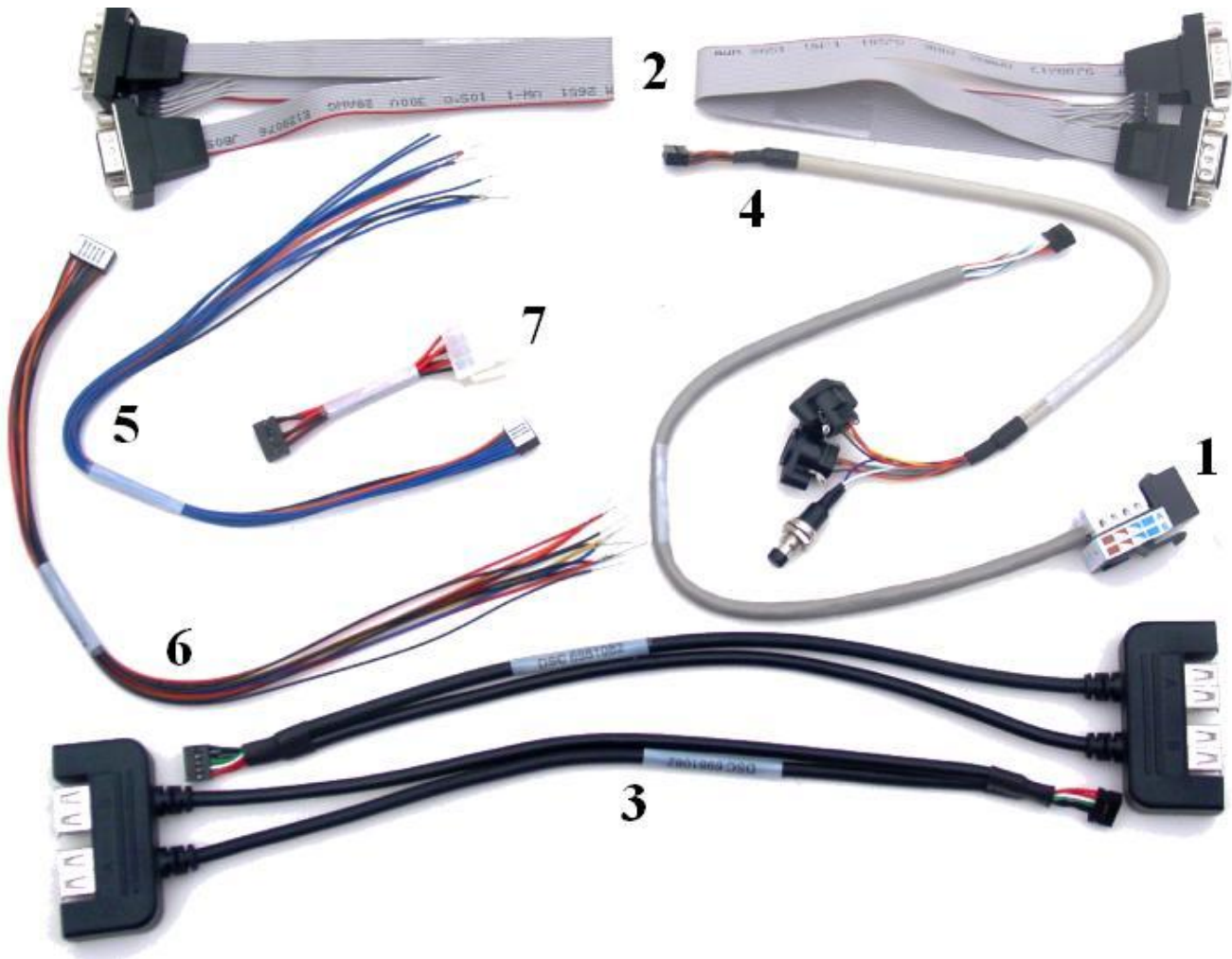

Note: On each interface cable, the end of the cable connector that has a red wire going to it should be oriented toward the end of the board connector that is labeled "pin 1" (typically the pin with a square pad on the PCB).

Item	Qty	Description	Diamond P/N	Connects to...
1	1	Ethernet cable, 2x5 2mm	6981080	LAN1
2	2	Dual Serial port cable, 2x20 2mm	6981081	COM1, COM2
3	2	Dual USB cable, 2x5 2mm	6981082	USB1, USB2
4	1	PS/2 Keyboard Mouse, 2x5 2mm	6981301	KBMS1
5	1	Digital I/O cable, 2x5 2mm	6981302	GPIO_P1
6	1	Power input cable, 2x6 2mm	6981303	PWR1
7	1	PS-5V-04 to Aurora power cable	6981307	PWR1

3.2 System Setup

This section outlines a simple process for preparing Aurora for first-time operation using the Aurora Development Kit. Additional details regarding Aurora's interface functions and connections may be found in Section 4 of this document ("Interface Connector Details").

3.2.1 Keyboard and Mouse

Aurora supports operation using PS/2-based keyboard and mouse devices. Plug the keyboard and mouse cable, 6981301, from the Aurora Cable Kit into the connector KBMS1 on Aurora. Then plug the keyboard and mouse into the mating connectors on the Aurora interface cables.

3.2.2 USB Flashdisk Socket

Aurora provides a location for on-board installation of an optional USB flashdisk on connector USB3. Plug the USB flashdisk module, 8890300, in the Development Kit into connector USB3 on Aurora. Remove the screw from the mounting stand-off before installing the flashdisk. Secure the flashdisk to Aurora with the screw once the flashdisk is installed.

3.2.3 Mass Storage Devices

If desired, connect SATA hard drives to Aurora by connecting a USB cable, part number 6981082, to connector USB1 and then to the SATA drive. Aurora can operate with a combination of SATA and CD-ROM drives, and can boot from either of them.

Caution! Be sure the PS-5V-01 AC power adapter is disconnected from its AC power source prior to performing the following step...

3.2.4 Connecting Power

Connect cable 6981307 to the PS-5V-01 AC power adapter. Connect the other end of the 6981307 cable to connector PWR1 on the Aurora SBC.

3.2.5 Display

Aurora provides interfaces for both LVDS flat panel displays and SDVO output. VGA CRTs can also be used via an external SDVO to VGA converter. This quick-start process assumes you are using the external VGA converter (number ACC-VGA-03) supplied with the development kit.

Install the I/O board provided in the ACC-VGA-03 kit on top of Aurora, aligning the PC/104 and SUMIT-A connectors. Connect the VGA cable supplied in the ACC-VGA-03 between the VGA connector on the I/O board and a VGA-compatible display.

3.2.6 Installing Aurora in an Enclosure (optional)

Follow these steps to install the Aurora single board computer in an enclosure that has an appropriate mounting-hole pattern:

- Remove the four screws in the corners of the heat-spreader attached to the bottom of the Aurora SBC.
- Align Aurora with the mounting-hole pattern that corresponds to screws you just removed.
- Attach the stack to the enclosure using the same four mounting screws. Depending on the thickness of the enclosure or chassis material, slightly longer screws may be required.

3.3 Booting the System

Power-up the VGA video monitor. Then plug the PS-5V-01 AC power adapter to an AC outlet. Aurora should begin its boot-up sequence immediately, as evidenced by BIOS messages on the connected VGA display. You can run the BIOS Setup utility and proceed to install an operating system on the boot drive just as you would on a normal desktop PC.

3.3.1 BIOS Setup

Aurora's BIOS provides a wide range of configuration options. When you power up Aurora for the first time, you should immediately enter the BIOS "Setup" utility in order to adjust BIOS settings to match your system's peripheral devices and other requirements, and to configure various other hardware and software parameters.

Options configurable via Setup typically include:

- Number and type of mass storage devices
- Boot device priority
- Video display type and resolution
- IDA, SATA, serial, and parallel interface modes and protocols
- PCI and PnP configuration
- Power management setup
- Automatic power-up after LAN connection, RTC alarm, power resumption, etc.
- System monitoring and security functions

3.3.2 Operating System Drivers

Aurora will boot and run a Linux 2.6 operating system from the USB flashdisk. Aurora should now be fully operational.

If you desire to run a different operating system, depending on the operating system to be installed, it may be necessary to install software drivers for on-board interface controllers. Drivers for Windows XP, XPe, and Linux 2.6, if required, are included on the Software and Documentation CD that is included in the Aurora Development Kit. This software is also available for download from the Aurora page at Diamond's website, www.diamondsystems.com/products/aurora.

4. INTERFACE CONNECTOR DETAILS

This section describes the functions associated with the Aurora baseboard's SUMIT-A bus, PCI-104 bus expansion stack, utility, I/O interfaces, and power connectors in greater detail. Section 3.1.1 contains a list of ready-to-use interface cables included in Diamond's Aurora Cable Kit.

4.1 SDVO Connector (SDVO1)

The SDVO connector provides differential pair video output signals.

An optional SDVO to VGA converter accessory, number ACC-VGA-03, interfaces with this connector and provides signals for directly driving VGA-interfaced CRTs and LCDs. The VGA converter I/O board provides a standard DE-15 VGA connector.

1	SDVO_B_BLUE#
2	BUF_PLT_RST#
3	SDVO_B_BLUE
4	Ground
5	Ground
6	SDVO_B_GREEN#
7	SDVO_CTRLCLK
8	SDVO_B_GREEN
9	SDVO_CTRLDATA
10	Ground
11	Ground
12	SDVO_B_CLK_N
13	+3.3V
14	SDVO_B_CLK_P
15	+3.3V
16	Ground
17	+5V
18	SDVO_B_RED#
19	+5V
20	SDVO_B_RED

PCB connector: SAMTEC ERM8-010-08.0-L-DV 20 pin 0,800 mm pin spacing

4.2 LCD Panel (LVDS Interface) Connector (LVDS1)

This connector is mounted on the bottom side of Aurora, directly below the SDVO connector, SDVO1. It provides connection to an LVDS LCD display. The LCD panel power is jumper-selectable for 3.3V (default) or 5V. Use Diamond's cable number 6981403 (ordered separately) to connect between LVDS1 and the LCD display.

1	Ground / D3+, depending on video chip
2	Ground / D3-, depending on video chip
3	Scan Direction (High = Reverse Scan, Low/open = Normal Scan)
4	Frame Rate Control (High = On, Low/open = Off)
5	Signal Ground
6	Pixel Clock +
7	Pixel Clock -
8	Signal Ground
9	D2+
10	D2-
11	Signal Ground
12	D1+
13	D1-
14	Signal Ground
15	D0+
16	D0-
17	Power Ground
18	Power Ground
19	Vcc 3.3V / 5V (jumper configured)
20	Vcc 3.3V / 5V (jumper configured)

PCB connector: JAE part no. FI-SE20P-HFE or equivalent

Cable-mount socket: JAE part no. FI-SE20S-2-L or equivalent

4.3 LCD Backlight Connector (INV1)

This connector provides the backlight power and control for the optional LCD panel. Use Diamond's cable number 6981404 (ordered separately) to connect between INV1 and the LCD backlight. The brightness control for the LCD backlight can be found on jumper JBKC1. Note: If needed, +12V must be provided on the input power connector.

1	Power +5V/+12V, jumper selectable
2	Power (same as pin 1)
3	Ground
4	Ground
5	Enable (GPIO output), 0 = off, open circuit = on
6	Brightness, 0-5VDC variable; 0V = max, 5V = min

PCB connector: Molex 53047-0610 or equivalent

Mating connector: Socket: Molex 51021-0600 or equivalent

Terminals: Molex 50058 / 50079 series or equivalent

4.4 SUMIT-A Expansion Bus (SUMITA1)

The SUMIT-A stackable bus is a 52-pin surface mount connector located on the expansion side of the board. Aurora implements the following SUMIT bus functions:

- 1 PCIe x1 lane
- 3 USB 2.0 channels
- LPC bus
- SMBus
- SPI, if a chip select is available from the embedded controller IC

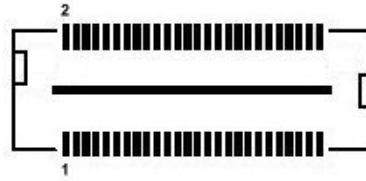

The standard signal assignments of the SUMIT-A connector appear in below. Note: For more information on the SUMIT specification, visit the SFF-SIG website at <http://www.sff-sig.org>.

+5VSB	1	2	+12V
3.3V	3	4	SMBDAT1_EC
3.3V	5	6	SMBCLK1_EC
EXCD0_CPPE#	7	8	SMBALERT#
EXCD0_PERST#	9	10	SPI_DOUT
USB_OCP4_5_6_7#	11	12	SPI_DIN
RSVD	13	14	SPI_CLK
+5V	15	16	SPI_EXT_CE#
Reserved	17	18	Reserved
Reserved	19	20	Reserved
+5V	21	22	Reserved
USB_PORT6_P_C	23	24	LPC_AD0
USB_PORT6_N_C	25	26	LPC_AD1
+5V	27	28	LPC_AD2
USB_PORT5_P_C	29	30	LPC_AD3
USB_PORT5_N_C	31	32	LPC_FRAME#
+5V	33	34	INT_SERIRQ#
USB_PORT4_P_C	35	36	PCIRST#
USB_PORT4_N_C	37	38	CLK_LPC2
Ground	39	40	Ground
PCIE_TXP2	41	42	PCIE_RXP2_SUMIT
PCIE_TXN2	43	44	PCIE_RXN2_SUMIT
Ground	45	46	PCIRST#
PCIRST#	47	48	CLK_PCIE_SUMIT
PCIE_WAKE#	49	50	CLK_PCIE_SUMIT#
+5V	51	52	Ground

4.5 Serial Ports (COM1, COM2)

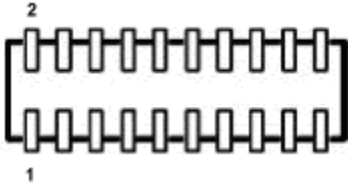

These connectors provide access to the board's four serial ports. Ports 1 and 2 are fixed for RS-232 only, while ports 3 and 4 may be jumper-configured for RS-232, RS-422, or RS-485 protocols. The connector pinout changes depending on the selected protocol. Aurora can be custom-ordered preconfigured for a selected protocol; it is also possible to order a fixed configuration with soldered-on zero ohm resistors, so no jumpers are used.

	RS-232 Configuration				RS-422 Configuration				RS-485 Configuration				
Port 1	DCD 1	1	2	DSR 1		1	2			1	2		
	RXD 1	3	4	RTS 1		3	4			3	4		
	TXD 1	5	6	CTS 1		5	6			5	6		
	DTR 1	7	8	RI 1		7	8			7	8		
	Ground	9	10	NC		9	10			9	10		
Port 2	DCD 2	11	12	DSR 2		11	12			11	12		
	RXD 2	13	14	RTS 2		13	14			13	14		
	TXD 2	15	16	CTS 2		15	16			15	16		
	DTR 2	17	18	RI 2		17	18			17	18		
	Ground	19	20	NC		19	20			19	20		
Port 3	DCD 3	1	22	DSR 3	NC	21	22	NC		NC	21	22	NC
	RXD 3	3	24	RTS 3	TXD+ 3	23	24	TXD- 3	TXD/RXD+ 3	23	24	TXD/RXD- 3	
	TXD 3	5	26	CTS 3	Ground *	25	26	RXD- 3	Ground *	25	26	NC	
	DTR 3	7	28	RI 3	RXD+ 3	27	28	NC	NC	27	28	NC	
	Ground	9	30	NC	Ground	29	30	NC	Ground	29	30	NC	
Port 4	DCD 4	11	32	DSR 4	NC	31	32	NC		NC	31	32	NC
	RXD 4	13	34	RTS 4	TXD+ 4	33	34	TXD- 4	TXD/RXD+ 4	33	34	TXD/RXD- 4	
	TXD 4	15	36	CTS 4	Ground	35	36	RXD- 4	Ground	35	36	NC	
	DTR 4	17	38	RI 4	RXD+ 4	37	38	NC	NC	37	38	NC	
	Ground	19	40	NC	Ground	39	40	NC	Ground	39	40	NC	

Connector type: Standard 2mm dual row straight pin header with 4mm posts and gold flash plating

4.6 PS/2 Keyboard/Mouse (KBMS1)

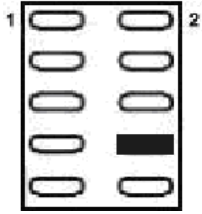

This connector provides the standard PS/2 keyboard and mouse signals.

+5V	1	2	No connection
KB Data	3	4	MS Data
KB Clk	5	6	MS Clk
KB Ground	7	8	Key
KB Ground	9	10	RESET BTN#

Connector type: Standard 2mm dual row straight pin header with 4mm posts and gold flash plating

4.7 External Battery (BAT1)

Aurora has provision for an external battery connection via BAT1, a two-pin connector.

A connector and jumper are provided to disable the on-board battery and enable use of an external battery instead. The external battery voltage requirement is 3.3V +/-10%. The jumper also clears the CMOS RAM when it is removed and no external battery is connected.

1	Ground
2	Battery+

Connector type: Shrouded 2mm header with key notch

4.8 PC/104 (ISA) Expansion Bus (PC104_1)

The PC/104 bus is essentially identical to the ISA Bus except for the physical design. It specifies two pin and socket connectors for the bus signals. A 64-pin header incorporates the 62-pin 8-bit bus connector signals, and a 40-pin header incorporates the 36-pin 16-bit bus connector signals. The additional pins on the PC/104 connectors are used as ground or key pins. The female sockets on the top of the board enable stacking another PC/104 board on top of the board, while the male pins on the bottom enable the board to plug into another board below it.

In the pinout figures below, the tops correspond to the left edge of the connector when the board is viewed from the primary side (side with the female end of the PC/104 connector) and the board is oriented so that the PC/104 connectors are along the bottom edge of the board.

Note: For more information on the PC/104 specification, visit the PC/104 Embedded Consortium website, at <http://www.pc104.org>.

View from Top of Board

PC/104 8-bit bus connector				PC/104 16-bit bus connector			
IOCHK-	A1	B1	Ground	Ground	C0	D0	Ground
SD7	A2	B2	RESET	MEMCS16	C1	D1	SBHE-
SD6	A3	B3	+5V	IOCS16-	C2	D2	LA23
SD5	A4	B4	IRQ9	IRQ10	C3	D3	LA22
SD4	A5	B5	-5V	IRQ11	C4	D4	LA21
SD3	A6	B6	DRQ2	IRQ12	C5	D5	LA20
SD2	A7	B7	-12V	IRQ15	C6	D6	LA19
SD1	A8	B8	OWS-	IRQ14	C7	D7	LA18
SD0	A9	B9	+12V	DACK0-	C8	D8	LA17
IOCHRDY	A10	B10	KEY	DRQ0	C9	D9	MEMR-
AEN	A11	B11	SMEMW-W	DACK5-	C10	D10	MEMW-
SA19	A12	B12	SMEMR-	DRQ5	C11	D11	SD8
SA18	A13	B13	IOW-	DACK6-	C12	D12	SD9
SA17	A14	B14	IOR-	DRQ6	C13	D13	SD10
SA16	A15	B15	DACK3-	DACK7-	C14	D14	SD11
SA15	A16	B16	DRQ3	DRQ7	C15	D15	SD12
SA14	A17	B17	DACK1-	+5V	C16	D16	SD13
SA13	A18	B18	DRQ1	MASTER-	C17	D17	SD14
SA12	A19	B19	REFRESH-	Ground	C18	D18	SD15
SA11	A20	B20	SYSCLK	Ground	C19	D19	KEY
SA10	A21	B21	IRQ7				
SA9	A22	B22	IRQ6				
SA8	A23	B23	IRQ5				
SA7	A24	B24	IRQ4				
SA6	A25	B25	IRQ3				
SA5	A26	B26	DACK2-				
SA4	A27	B27	TC				
SA3	A28	B28	BALE				
SA2	A29	B29	+5V				
SA1	A30	B30	OSC				
SA0	A31	B31	Ground				
Ground	A32	B32	Ground				

4.9 Input Power (PWR1)

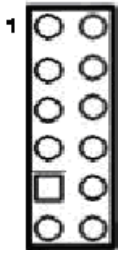

The power signals on this connector come from a connector leading to the output from a DC/DC power supply installed in the system.

Ground	1	2	+5VDC
Ground	3	4	+12VDC
Ground	5	6	
Ground	7	8	+5VDC
Key	9	10	+5VDC
Ground	11	12	Ext Bat1

Connector type: Standard dual row 2mm pitch straight pin header with gold flash plating

4.10 Ethernet (LAN1)

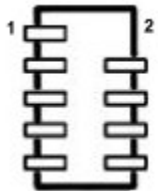

This connector provides access to the board's gigabit Ethernet port.

Common	1	2	Key
DA+	3	4	DA-
DB+	5	6	DB-
DC+	7	8	DC-
DD+	9	10	DD-

Connector type: Standard 2mm dual row vertical pin header with 4mm posts and gold flash plating

4.11 USB 0-1 (USB1)

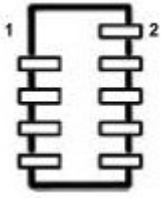

This connector provides access to two of the board's four USB 2.0 ports, USB0 and USB1. The shield pin is tied to system ground.

Key	1	2	
			Shield
USB1 Pwr-	3	4	USB0 Pwr-
USB1 Data+	5	6	USB0 Data+
USB1 Data-	7	8	USB0 Data-
USB1 Pwr+	9	10	USB0 Pwr+

Connector type: Standard 2mm vertical pin header with 4mm posts and gold flash plating

4.12 USB 2-3 (USB2)

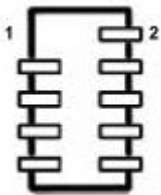

This connector provides access to two of the board's four USB 2.0 ports, USB2 and USB3. The shield pin is tied to system ground.

Key	1	2	
			Shield
USB3 Pwr-	3	4	USB2 Pwr-
USB3 Data+	5	6	USB2 Data+
USB3 Data-	7	8	USB2 Data-
USB3 Pwr+	9	10	USB2 Pwr+

Connector type: Standard 2mm dual row vertical pin header with 4mm posts and gold flash plating

4.13 USB Flashdisk (USB3)

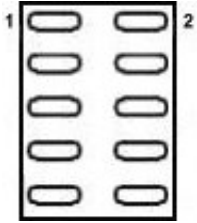

This connector is used for the USB on-board flashdisk interface. This is a dedicated USB port.

USB7 Pwr+	1	2	NC
USB7 Data-	3	4	NC
USB7 Data+	5	6	NC
USB7 Pwr-	7	8	NC
NC	9	10	NC

Connector type: Standard 2mm dual straight pin header with 4mm posts and gold flash plating

4.14 SO-DIMM DRAM (SODIMM1)

A standard SO-DIMM DDR2 DRAM connector is provided for system memory.

4.15 SATA (SATA1)



The SATA connector is an industry-standard connector.

1	Ground
2	Transmit+
3	Transmit-
4	Ground
5	Receive-
6	Receive+
7	Ground

Connector type: SAMTEC ERM8-010-08.0-L-DV 20 pin 0,800 mm pin spacing

4.16 GPIO (GPIO_P1)

The GPIO connector is a standard 2mm dual row vertical pin header with 4mm posts and gold flash plating.

GPIO0	1	2	GPIO1
GPIO2	3	4	GPIO3
GPIO4	5	6	GPIO5
GPIO6	7	8	GPIO7
Ext. Reset Input	9	10	Ground

Connector type: Standard 2mm dual row vertical pin header with 4mm posts and gold flash plating

5. CONFIGURATION JUMPER DETAILS

This section explains the use of several jumper options on the Aurora Baseboard.

<i>Jumper Group Function</i>	<i>Silkscreen Label</i>	<i>Array Size</i>
LCD Panel Power Select (3.3V/5V)	JVLCD1	1 x 3
LCD Backlight Brightness Control	JBKC1	2 x 2
LCD Backlight Power (5V/12V)	JINV1	1 x 3
LCD Scan Direction	JLCD1	2 x 2
Internal or External SPI Flash	JSP1 SEL1	1 x 3
Serial Ports 3 and 4 RS-422/485 configuration	JCOM3, JCOM4	2 x 5
CMOS RAM Reset / On-Board Backup Battery Disconnect	JBAT1	1 x 3

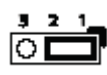
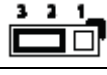

5.1 LCD Panel Power Select - 3.3V/5V (JVLCD1)

This jumper group must be configured according to input voltage required by the type of LCD panel that will be attached to Aurora's LCD panel interface connector.

<i>Setting</i>	<i>LCD Panel Voltage</i>	
Short 1-2	+5V	
Short 2-3	+3.3V (default)	



5.2 LCD Backlight Brightness Control (JBKC1)

This jumper group controls the LCD brightness selection.

Setting	Mode	
Short 1-2	Brightness set by chipset Backlight control	
Short 3-4	Brightness set by Display Data Channel PWM (default)	



5.3 LCD Backlight Power (JINV1)

This jumper group controls the LCD backlight inverter DC power selection.



Setting	LCD Panel Voltage	
Short 1-2	+5V (default)	
Short 2-3	+3.3V	

5.4 LCD Scan Direction (JLCD1)

This jumper group controls the LCD panel scan direction and frame rate control.



Setting	Mode	
Short 1-2	Reverse Scan Direction	
Short 3-4	Forward Scan Direction (default)	

5.5 Internal or External SPI Flash (JSP1 SEL1)

Setting	LCD Panel Voltage	
Short 1-2	Internal SPI Flash (default)	
Short 2-3	External SPI Flash	

5.6 CMOS RAM Reset / On-board Backup Battery Disconnect (JBAT1)

This jumper group controls the external battery backup enable settings.

Setting	Mode	
Short 1-2	Backup battery connected (default)	
Short 2-3	Clear CMOS	

5.7 Serial Ports (JCOM3, JCOM4)

Following is the Aurora multi-protocol jumper selection for COM3, COM4. Port COM3 is associated with jumper block JCOM3, and COM4 is associated with JCOM4.

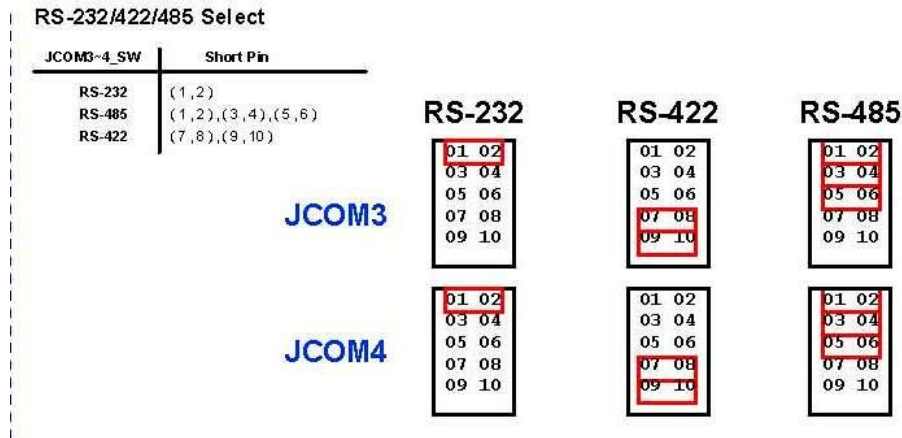

6. BIOS

Aurora's BIOS provides access to many valuable features. These instructions show how to enter the BIOS, set up features, and restore the BIOS to its default settings.

6.1 Entering the BIOS

The BIOS may be entered during startup by pressing the **DEL** key on an attached keyboard or pressing **F4** if using console redirection. Press the key repeatedly right after power-on or reset until the BIOS screen appears.

After a certain amount of time during startup, the BIOS will ignore the DEL or F4 key. If you wait too long and the system does not respond, simply reset the system (or power down) and try again.

6.2 Restoring Default BIOS Settings

In order to load the default BIOS settings, turn off the system and install a jumper on pins 2-3 of jumper block JBAT1, located on the bottom right corner of the board. This will clear CMOS and reset the BIOS to the default settings. After three seconds put the jumper back to position 1-2 and turn the system on.

On the first screen after booting up, the user will be asked to press **F1** to run SETUP, or **F2** to load the defaults.

6.3 Setting the Date and Time

The date and time are set in the BIOS. Select **Main** menu, then enter the date and time at the bottom of the screen. This screen also displays the CPU speed and memory capacity of the board.

6.4 ISA Bus IRQ Reservation

An ISA bus IRQ must be reserved in the BIOS in order to be used by the on-board ISA bus circuits or an installed PC/104 module. To reserve an IRQ, go to the **PCIPnP** menu and scroll down to the IRQ list at the bottom. The default settings are IRQ15 reserved with the remaining IRQs available.

6.5 Boot Priority

To select Boot devices and set their priority, go to the **Boot -> Boot device priority** menu and select the first boot device from the list.

Upon clicking on the first boot device, a window with the available devices will open. The user can select any of the devices as the first boot device.

The devices can be a SATA HDD, a network drive, or a USB device.

The USB device present in this list is the first Drive defined in the "USB Drives" Menu.

Here are the steps to select a USB drive to boot from:

1. Boot-> USB Drives -> 1st Drive -> (select a USB device from the list)
2. Boot->Boot Device Priority-> 1st Boot device (select the USB device which has been defines in line 1)

In this way, the system will try to boot from the USB device. The same procedure applies for other boot devices (2nd, 3rd,...).

6.6 Chipset

The chipset menu is provided to define and change the North / South Bridge options such as Graphic Adapter Modes, flat panel type (default is 800x600), and enable/disable on-board PCI3 line and Ethernet adapter.

By default, both PCIe and LAN controllers are enabled. This can be changed in the South Bridge menu.

6.7 Super I/O Configuration

This is to set the address/IRQ of the four serial ports. COM3 and COM4 are capable of RS-232/422/485 protocols; whereas COM1 and COM2 can only be set to RS-232.

6.8 Console Redirection

In the advanced menu, the user can select any of the serial ports for console redirection with different speeds ranging from 115200bps to 9600bps as follows.

Advanced - Remote Access Configuration - Disabled (Default)

When set to Enabled, the console re-direction is activated on COM1 by default at 115200,n,8,1 communication settings. The remote access configuration can be enabled on any of the four COM ports. Baud rates supported are 115200 (default when enabled), 57600, 38400, 19200 and 9600.

7. DIGITAL I/O LINES

Aurora has eight digital I/O lines found on connector GPIO_P1. This connector has one pin for each line plus an External Reset Input and Ground line.

7.1 DIO Registers

Aurora's digital I/O lines are associated with a set of registers as shown in the following table.

<i>Register</i>	<i>EC RAM</i>	<i>Read/Write</i>	<i>Description</i>
DIO_P0_DIR	1658h	R/W	DIO port direction bits: Output: 0x40 Input: 0x80
DIO_P1_DIR	1659h	R/W	
DIO_P2_DIR	165Ah	R/W	
DIO_P3_DIR	165Bh	R/W	
DIO_P4_DIR	165Ch	R/W	
DIO_P5_DIR	1614h	R/W	
DIO_P6_DIR	1615h	R/W	
DIO_P7_DIR	1616h	R/W	
DIO_P0_LVL	160Ah[bit0]	R/W	DIO level: 1: High 0: Low
DIO_P1_LVL	160Ah[bit1]	R/W	
DIO_P2_LVL	160Ah[bit2]	R/W	
DIO_P3_LVL	160Ah[bit3]	R/W	
DIO_P4_LVL	160Ah[bit4]	R/W	
DIO_P5_LVL	1601h[bit5]	R/W	
DIO_P6_LVL	1601h[bit6]	R/W	
DIO_P7_LVL	1601h[bit7]	R/W	
			Note: Do not modify any other bits

7.2 DIO Programming

To use Aurora's digital I/O lines, first configure the desired directions by writing the appropriate configuration value to the digital I/O lines' register. Then read or write data on the digital I/O lines' level register. All I/O lines are in read mode on power-up or after a board reset. Sample code for reading and writing to the digital I/O lines follows.

```

unsigned long Process_686C_Command_Write(ULONG m_ECCMD, ULONG m_ECDATA)
{
//-----
Int    i,temp;
ULONG m_OutBuf;
//-----
m_OutBuf=Read_io_port(0x6C);
if ( ( m_OutBuf&0x00000003) > 0 )
{
    temp=Read_io_port(0x68);
    return 0xFFFFFFFF;
}
}

```

```

Write_io_port(6C,m_ECCMD);
for ( i=0; i<=4000; i++ )
{
    m_OutBuf=Read_io_port(0x6C);
    if ( ( m_OutBuf&0x00000002) == 0 ) break;
}
if ( i < 3999 )
{
    Write_io_port(0x68,m_ECADATA);
    for ( i=0; i<=4000; i++ )
    {
        m_OutBuf=Read_io_port(0x6C);
        if ( ( m_OutBuf&0x00000002) == 0 )
            { return 0x00000000; }
    }
}

if ( i > 3999 ) m_OutBuf=Read_io_port(0x68);
return 0xFFFFFFFF;
}
//-----

unsigned long Process_686C_Command_Read(ULONG m_ECCMD )
{
int i,temp;
    ULONG m_OutBuf,m_InBuf;
    m_OutBuf=Read_io_port(0x6C);
    if ( ( m_OutBuf&0x00000003) > 0 )
        {
            temp=Read_io_port(0x68);
            return 0xFFFFFFFF;
        }
m_InBuf = m_ECCMD;
Write_io_port(0x6C,m_InBuf);
for ( i=0; i<=3500; i++ )
{
    m_OutBuf=Read_io_port(0x6C);
    if ( ( m_OutBuf&0x00000001) > 0 )
        {
            temp=Read_io_port(0x68);
            temp= (temp & 0x000000FF) ;
            return temp;
            break;
        }
}
}
if ( i > 3499 )
{
    temp=Read_io_port(0x68);
    return 0xFFFFFFFF;
}
}
//-----

```

```
unsigned long ECU_Read_686C_RAM_BYTE( ULONG ECUMemAddr )
{
    ULONG uDATA1,uDATA2,ECRamAddrH,ECRamAddrL;
    ECRamAddrL=ECUMemAddr%256; ECRamAddrH=ECUMemAddr/256;
    //
    uDATA1=Process_686C_Command_Write(0x000000A3, ECRamAddrH );
    if ( uDATA1==0xFFFFFFFF ) { return 0xFFFFFFFF; }
    //
    uDATA1=Process_686C_Command_Write(0x000000A2, ECRamAddrL );
    if ( uDATA1==0xFFFFFFFF ) { return 0xFFFFFFFF; }
    //
    uDATA1=Process_686C_Command_Read( 0x000000A4 );
    if ( uDATA1 > 0x000000FF ) { return 0xFFFFFFFF; }
    uDATA2=Process_686C_Command_Read( 0x000000A4 );
    if ( uDATA2 > 0x000000FF ) { return 0xFFFFFFFF; }
    if (uDATA1==uDATA2) return uDATA1;
    else return 0xFFFFFFFF;
}
//-----
```

```
unsigned long ECU_Write_686C_RAM_BYTE( ULONG ECUMemAddr,ULONG ECUMemData )
{
    ULONG uDATA, RD_DATA, ECRamAddrH, ECRamAddrL;
    ECRamAddrL=ECUMemAddr%256; ECRamAddrH=ECUMemAddr/256;
    //
    uDATA=Process_686C_Command_Write(0x000000A3, ECRamAddrH );
    if ( uDATA==0xFFFFFFFF ) { return 0xFFFFFFFF;}
    //
    uDATA=Process_686C_Command_Write(0x000000A2, ECRamAddrL );
    if ( uDATA==0xFFFFFFFF ) { return 0xFFFFFFFF;}
    //
    uDATA=Process_686C_Command_Write(0x000000A5, ECUMemData );
    if ( uDATA==0xFFFFFFFF ) { return 0xFFFFFFFF;}
    //
    return 0x00000000;
}
//-----
```

8. WATCHDOG TIMER

One watchdog timer is provided for system control with a WDTOUT# signal. The base address for the watchdog timer is 0x300. The watchdog timer has a default hardware setting defined at power on which sets the timer to 10 seconds. The interval also can be programmed by registers for a 10ms, 1s or 1 minute timeout. Upon timeout, the timeout trigger pulls the tri-state signal, WDTOUT#, low.

8.1 Registers

Timer Status and Control Register – Base + 0

<i>Bit</i>	<i>Register</i>	<i>Read/Write</i>	<i>Description</i>
7:3	Reserved	R/W	Return 0 when read
2:1	WDT_UNIT[1:0]	R/W	00: timer unit is 10ms 01: timer unit is 1 second 10: timer unit is 1 minute 11: reserved
0	WDT_EVENT	R/W	Read 0: no time out occurred 1: time out has occurred Write 0: no action 1: clear the time out status

Power-on default [7:0] = 0x02 when DTR3#/PS_WDT is pulled-up, else 0x0.

Timer Count Number Register – Base + 1

<i>Bit</i>	<i>Register</i>	<i>Read/Write</i>	<i>Description</i>
7:0	WDT_CNT[7:0]	R/W	Read: the current count of the watchdog timer Write: the same value to enable the timer 0 to disable the timer

Power-on default [7:0] = 0x0Ah when DTR3#/PS_WDT is pulled-up, else 0x00h.

8.2 Programming Sample Code

Following is sample code for programming Aurora's watchdog timer. The base address for the watchdog timer is 0x300.

```

/*          */
/*      Fintek F81216D Watchdog Timer sample code */
/*          */
/*----- Include Header Area -----*/
#include "math.h"
#include "stdio.h"
#include "dos.h"

/*----- routing, sub-routing -----*/
void main()
{

    printf(" i0158-Fintek F81216D WDT Utility Program Ver:0.2 \n");

    outportb(0x2e, 0x77);
    outportb(0x2e, 0x77); //Entry configuration mode

    outportb(0x2e, 0x07); //Select register index 0x07
    outportb(0x2f, 0x08); //Select LDN 8

    outportb(0x2e, 0x60); //Select LDN 8 register index 0x60
    outportb(0x2f, 0x03); //Set Watch Dog timer base address high byte to 0x03
    outportb(0x2e, 0x61); //Select LDN 8 register index 0x61
    outportb(0x2f, 0x00); //Set Watch Dog Timer base address low byte to 0x00

    outportb(0x2e, 0x30); //Select LDN 8 register index 0x30
    outportb(0x2f, 0x01); //Enable Watch Dog Timer Device

    outportb(0x2e, 0xaa); //Exit configuration mode

                                //Timer Status and control Register - Base + 0
                                //bit 2:1 R/W          00:Timer Unit is 10 ms
                                //                                01:Timer Unit is 1 Second
                                //                                10:Timer Unite is 1 minute.
                                //                                11:reserved
                                //-----
                                //bit 0          R/W          When read
                                //                                0:no time out occur.
                                //                                1:time out has occurred.
                                //                                When write
                                //                                0:no action
                                //                                1:clear time out status
    outportb(0x300, 0x03); //Select unit to one second and clear time out status

                                //Timer Count Number Register - Base + 1
                                //bit 7:0 R/W      Their number of count for watchdog timer.
                                // Write the same value to enable the timer, write 0 to disable timer.
    outportb(0x301, 0x05);
    outportb(0x301, 0x05); //Set timer to 5 second and enable timer

}

```

The demo code above is an example for DOS. The same demo code has been ported for Linux and Windows XP OS and can be downloaded from the Diamond Systems web-site at www.diamondsystems.com/products/aurora.

9. FLASHDISK MODULES

9.1 Overview

Aurora is designed to accommodate an optional wide-temperature solid-state USB flashdisk module for rugged mass storage in place of a notebook hard drive or commercial flashdisk. This module contains 1GB to 8GB of solid-state non-volatile memory that operates like any USB hard disk drive without requiring additional driver software support. It features automatic wear leveling and 1,000,000 write cycles minimum.



USB Flashdisk

9.2 Models and Capacities

<i>Model</i>	<i>Capacity</i>
FDU-1G-XT	1GB
FDU-2G-XT	2GB
FDU-4G-XT	4GB
FDU-8G-XT	8GB

9.3 Features

The flashdisk module works just like a USB disk drive and requires no drivers. It provides high-speed nonvolatile mass storage in capacities of 1GB to 8GB. The flashdisk mounts on connector USB3 and is held in place with a spacer and screw (included). It includes a write protection jumper and operates over -40°C to +85°C.

USB flashdisk features:

- USB 2.0 compatible interface
- Sustained read performance of 30MB/s
- Sustained write performance of 20MB/s
- Implements dynamic wear-leveling algorithms to substantially increase longevity
- BCH (6/12 bit) Error Detection Code/Error Correction Code (EDC/ECC0)
- Intrinsic data integrity after power loss
- Wear leveling algorithm provides more reliable data storage over time
- Write protection setting by jumper for prevention of data overwrites
- Supports boot function for Windows Embedded Standard, Windows Embedded CE, and Linux
- Low power consumption, typical 110mA when active and 0.45mA in sleep mode
- -40°C to +85°C operation
- RoHS compliant

9.4 Flashdisk Installation

Installing a USB flashdisk module on Aurora is straightforward using the following steps.

1. Ensure power is disconnected from Aurora.
2. Remove the screw from the standoff located between the flashdisk connector, USB3, and the PC/104 connector.
3. Align the flashdisk so that its female connector aligns with the pins on connector USB3 and the mounting hole aligns above the standoff.
4. Press the flashdisk downward onto connector USB3.
5. Reinstall the screw, securing the flashdisk module to Aurora.

10. RUGGEDIZED SO-DIMM MODULES

Aurora comes with ruggedized SO-DIMM SDRAM modules for improved performance in high shock and vibration environments. These modules securely affix to the Aurora single board computer through a pair of standoffs and screws. This innovative design ensures that the SO-DIMM module remains fixed in place and cannot back out of its socket.

These ruggedized SO-DIMM modules are identical in function to the standard SO-DIMMs, but have an extended PCB with two mounting holes that attach to Aurora as can be seen below.



Ruggedized SO-DIMM Module

10.1 Models and Capacities

<i>Model</i>	<i>Capacity</i>
MEM-1024R-05	1GB
MEM-2048R-05	2GB

10.2 SO-DIMM Memory Installation

Installing a SO-DIMM memory module on Aurora is straightforward using the following steps. These steps assume you are installing a rugged memory SO-DIMM from Diamond Systems. If no, please disregard steps 2 and 6.

1. Ensure power is disconnected from Aurora.
2. Remove the two screws from the two standoffs located between the SO-DIMM connector and the edge of the board.
3. Insert the SO-DIMM module into the socket at a slight angle, approximately 30 degrees. The socket and module are both keyed, which means the module can be installed one way only.
4. To seat the module into the socket, apply firm, even pressure to each end of the module until you feel it slip down into the socket.
5. With the module properly seated in the socket, rotate the module downward, as indicated in the illustration. Continue pressing downward until the clips at each end of the socket lock into position.
6. Reinstall the two screws into the standoffs, securing the SO-DIMM to Aurora.

11. PANEL I/O BOARD

The Aurora panel I/O board, model PNL-AUR-01, provides a convenient way to access most of the SBC's I/O features without the use of cables. The bottom side contains 2mm female sockets that plug on top of the SBC and convert the SBC I/O pin headers to industry-standard connectors on the top side. Available I/O includes:

- ◆ 4 serial ports
- ◆ 4 USB ports
- ◆ VGA
- ◆ Ethernet
- ◆ PS/2 Keyboard & mouse

The panel I/O board may be used together with the Aurora SBC in an “open frame” configuration, or the assembly can be installed in a Pandora enclosure to create a complete, cable-free, compact industrial computer.



Aurora Panel I/O Board, User Side



Aurora Panel I/O Board, SBC Side

11.1 Mechanical Drawing

Figure 6 shows the panel I/O board connector layout. This drawing shows both the top side and bottom side connectors in one drawing to show the relative locations. The connectors located on the bottom of the panel I/O board are the five alternate power connectors at the bottom of the drawing below: JMM OUT (J2), JMM IN (J6), JMM IN (J5), REG5V (J3), and 12V/VIN (J4), from left to right looking from the top.

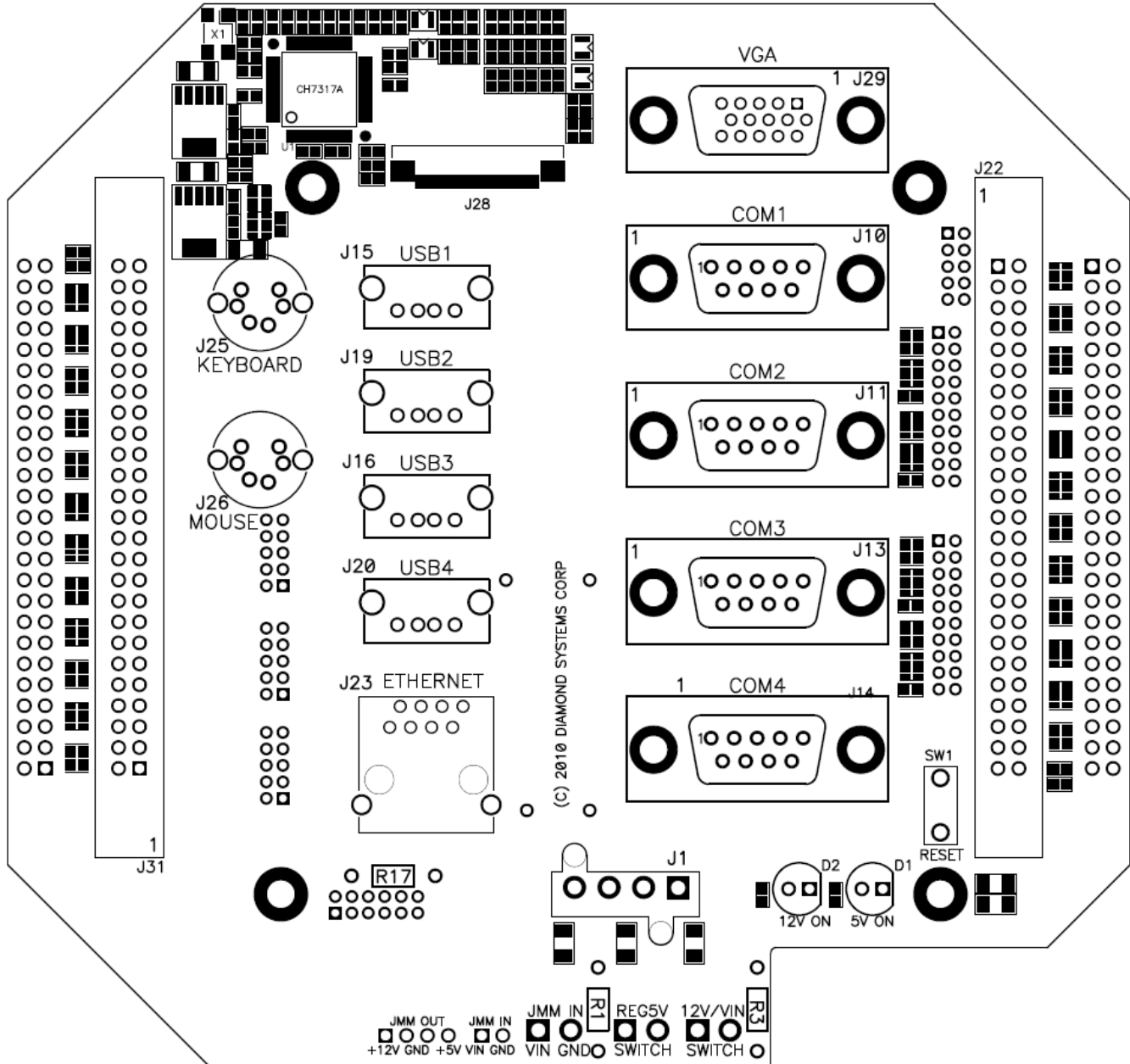

Figure 6: Aurora Panel I/O Board Connectors

11.2 Outside Facing I/O Connectors

These connectors are on the top side of the board. They face out through the enclosure front panel. All connectors must be compatible with the specified distance of 7mm between the top panel and the panel I/O board.

11.2.1 Input Power (J1)

The input power connector, J1, is Molex part number 39-30-2045 or equivalent. Each pin has a 6A or greater current carrying capacity.

Input power may be supplied either as +5VDC, +5V/+12V DC or as Vin. The +5V and +12V are intended to be switched directly to the PC/104 bus power pins via the external power switch. The Vin is intended to be switched to an auxiliary connector on the back side of the board which is used to connect to a DC/DC power supply. The output of the DC/DC power supply is then fed either to the PC/104 bus power pins (if the power supply is on the PC/104 bus) or back to the panel board and then to the Aurora CPU through the +5V pins on the SBC mating power input connector.

1	+12V or Vin
2	Ground
3	Ground
4	+5V In

11.2.2 Ethernet (J23 Ethernet)

The Ethernet connector, J23, is a vertical metal-shielded RJ-45 jack with industry standard pinout for gigabit Ethernet.

Proper isolation must be maintained on all Ethernet signal routing to meet industry standard signal isolation specifications. No ground or power plane should be above or underneath these signals.

11.2.3 VGA (VGA)

The VGA connector is standard vertical DD15 female connector with industry standard VGA pinout. It has 4-40 thread inserts and hex screwlocks. The signals come from the SBC mating VGA connector.

11.2.4 USB (USB1, USB2, USB3, USB4)

The USB connectors are four vertical metal shrouded type A connectors with industry standard pinout for USB. The signals come from the two SBC mating USB connectors.

11.2.5 PS/2 Keyboard and Mouse (J25 Keyboard, J26 Mouse)

The PS/2 connectors are two vertical Mini-DIN-6 connectors with industry standard pinout for PS/2 keyboard and mouse. The signals come from the SBC mating PS/2 connector.

11.2.6 Serial Ports (COM1, COM2, COM3, COM4)

The serial port connectors are four vertical DB9 male connectors. They have 4-40 thread inserts and hex screwlocks. Ports 1-4 signals come from the two 20-pin SBC serial port connectors and each port connector uses the pinout shown below. To prevent EMI problems, ferrite bead packs are installed on the panel I/O board on the signal and ground connections to the DB9 connectors.

DB9 Pin	RS485 Signal Name	RS422 Signal Name	RS232 Signal Name	Serial Port Connector		RS232 Signal Name	RS422 Signal Name	RS485 Signal Name	DB9 Pin
1	NC	NC	DCD	1	2	DSR	NC	NC	6
2	D+	TX+	RXD	3	4	RTS	TX-	D-	7
3	GND	GND	TXD	5	6	CTS	RX-	NC	8
4	NC	RX+	DTR	7	8	RI	NC	NC	9
5	GND	GND	GND	9	10	NC	NC	NC	

11.3 Power Routing

There are two paths for input power. A +5VDC source, a +5V/12V source, or a variable input voltage source can be connected to the Aurora SBC power connector, or it can be connected to an external power supply source that provides +5V and +12V power to the PC/104 bus in the stack.

The panel I/O board also provides a path for optional +12VDC output from a power supply to the Aurora SBC through the pin socket.

The panel I/O board contains two green LEDs which are connected to the +5VDC and +12V/VIN signals to indicate power status.

There is also a 3.5V lithium battery mounted on the board to provide standby voltage to the CMOS/RTC unit on Aurora. The battery is a LTC-7PN or equivalent type with 4 pins and is soldered on the panel board without a socket for rugged-environment applications.

The schematic in Figure 7 indicates the power routing between the input power connector and Aurora through the panel I/O board. Power may be provided in several methods:

1. +5V (and +12V) in from the input power connector directly to the panel I/O board, using either the front panel switch or a direct connection, and then to the Aurora SBC through the input connector (PWR1).
2. Vin (+8-30VDC) from the input power connector to a connector leading to an internal DC/DC power supply, whose output is driven directly onto the PC/104 bus using the PC/104 bus connectors on the DC/DC power supply. The Vin may be routed to the power supply connector either through the front panel switch or through a direct connection.

The +5V source is connected to the board by a 1x4 0.200" locking connector, routed through a 1x2 0.156" pitch friction lock connector for a front panel switch and then to a pin socket on the bottom side that mates with Aurora. If +12V is also needed it is connected to the board by the same 1x4 connector, routed through a separate 1x2 0.156" friction lock connector for a front panel switch and then to the same pin socket on the bottom side that mates with Aurora. In this case the switch would be DPDT type instead of the SPDT type used by 5V or 12V only. The switch connectors can be bypassed with jumpers if desired.

The variable input voltage source is routed through another 1x2 .1" pitch friction lock connector for a front panel switch and then to a separate 1x2 0.156" pitch or 1x2 0.100" pitch friction lock connector for connection to a DC/DC power supply mounted inside the enclosure. The +5VDC output of this DC/DC power supply then has two paths to Aurora: (1) It can connect directly to the PC/104 bus of the system, if the power supply is mounted on the bus; or (2) it can be routed back to the panel I/O board with another connector and then to Aurora through the panel I/O board's pin socket connection.

The switch bypass jumpers are 0-ohm ¼ watt T/H resistors. To use the panel power switch, the resistor is cut away, opening the circuit.

The +12 input option jumper is used to enable +12V to be supplied through the Vin pin on the front panel connector. In this case both +5V and +12V would be supplied through the front panel connector. This jumper is a 0-ohm ¼ watt T/H resistor.

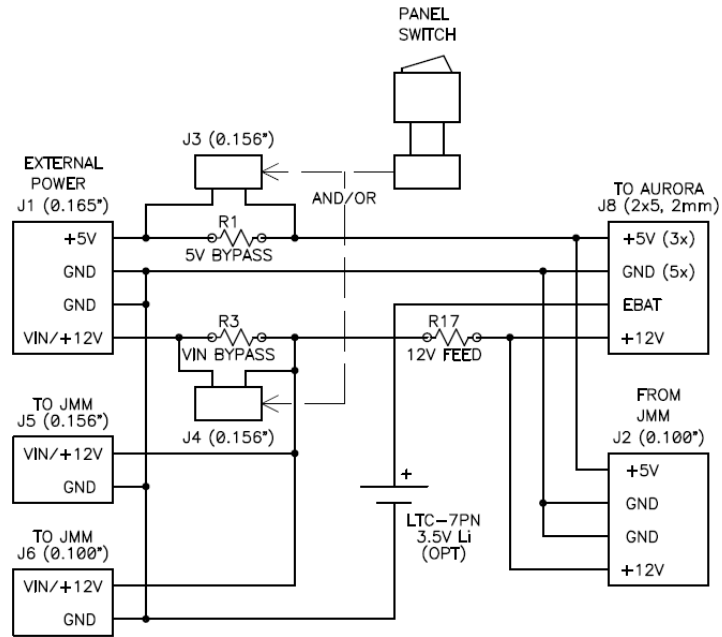

Figure 7: Power Routing Schematic

12. THERMAL PAD

A thermal pad is included with every Aurora. It is the same size as the heatspreader and attaches to the bottom of the heatspreader, but is shipped loose with the product. Customers can choose to affix the thermal pad or not depending on their needs. The specifications for the thermal pad are as follows.

- Material: 3M 5590H
- Color: Light Grey
- Thickness: 0.5/1.0 mm
- Thermal Conductivity: 3.0 W/m-K

13. SPECIFICATIONS

- Processor: Intel Atom Z530P at 1.6GHz
- Cooling : Heatspreader, fanless
- Memory: Up to 2GB ruggedized SO-DIMM DDR2 DRAM
- Display options:
 - LVDS flat panel interface
 - SDVO (optional VGA adapter)
- LVDS backlight power: +5V or +12V jumper selectable
- USB ports: 4 USB 2.0
- Serial ports: 2 RS-232/422/485, 2 RS-232
- Networking: 1 Gigabit Ethernet
- Mass storage:
 - 1 SATA port
 - Support for USB flashdisk
- Keyboard/Mouse PS/2, with BIOS support for USB
- Digital I/O: 8 digital I/O
- Watchdog Timer Yes
- PCI Express: 1 PCIe x1 lane to SUMIT-A bus
- Expansion buses: SUMIT-A stackable, PC/104 (ISA) stackable
- Input power: 5V \pm 5%
- Power consumption: 5.4W
- Operating temp. : -20°C to +71°C (-2°F to +160°F)
- MTBF: 211,720 hours
- Dimensions: 3.55" x 3.775" x 0.9" (90mm x 96mm x 23mm)
- Weight: 7.5oz / 212g