

# **HESC104+ Manual**

## ***High Efficiency & Smart Charging* Vehicle Power Supply DC to DC Converter**

Manufactured by  
**TRI-M ENGINEERING**

Engineered Solutions for Embedded Applications

### **Technical Manual**

P/N: HESC104+MAN

18 April 2006

**TRI-M ENGINEERING**

1407 Kebet Way, Unit 100  
Port Coquitlam, BC V3C 6L3  
Canada

<http://www.Tri-M.com>

Tel 604.945.9565

North America 800.665.5600

Fax 604.945.9566

## Table of Contents

<b>CHAPTER 1</b>	<b>INTRODUCTION.....</b>	<b>4</b>
1.1	GENERAL DESCRIPTION .....	4
1.2	FEATURES .....	4
1.3	SPECIFICATIONS .....	6
<b>CHAPTER 2</b>	<b>CONFIGURATION AND INSTALLATION .....</b>	<b>7</b>
2.1	INTRODUCTION .....	7
2.2	POWER CONSIDERATIONS. ....	7
2.2.5	<i>Main (CN2) and Secondary (CN3) Input Power Connector</i> .....	8
2.2.5	<i>Output Power Connector</i> .....	8
2.2.5	<i>Battery Connector</i> .....	8
2.2.5	<i>Aux Battery Connector</i> .....	9
2.2.5	<i>PCI-104 Bus Connector</i> .....	9
2.3	JUMPER SELECTION .....	10
2.3.5	<i>LED Jumper Enable/Disable</i> .....	10
2.3.2	<i>PCI ID Select (JP1)</i> .....	11
2.3.3	<i>PCI Clock Select (JP2)</i> .....	11
2.3.4	<i>PCI Interrupt Select (JP3)</i> .....	11
2.3.5	<i>PCI I/O voltage Select (JP4)</i> .....	11
<b>CHAPTER 3</b>	<b>POWER MANAGEMENT FEATURES.....</b>	<b>12</b>
3.1	INTRODUCTION.....	12
3.2	INPUT AND OUTPUT ACTIVE POLARITY .....	12
<b>CHAPTER 4</b>	<b>EXTERNAL BATTERY DESIGN .....</b>	<b>14</b>
1.1	BATTERY ISOLATION .....	14
1.2	DIGITAL SENSOR INTERFACE.....	14

## PREFACE

*This manual is for integrators of applications of embedded systems. It contains information on hardware requirements and interconnection to other embedded electronics.*

## DISCLAIMER

*Tri-M Engineering makes no representations or warranties with respect to the contents of this manual, and specifically disclaims any implied warranties of merchantability or fitness for any particular purpose. Tri-M Engineering shall under no circumstances be liable for incidental or consequential damages or related expenses resulting from the use of this product, even if it has been notified of the possibility of such damages. Tri-M Engineering reserves the right to revise this publication from time to time without obligation to notify any person of such revisions. If errors are found, please contact Tri-M Engineering at the address listed on the title page of this document.*

## COPYRIGHT © 2000-03-22 TRI-M ENGINEERING

*No part of this document may be reproduced, transmitted, transcribed, stored in a retrieval system, or translated into any language or computer language, in any form or by any means, electronic, mechanical, magnetic, optical, chemical, manual, or otherwise, without the express written permission of Tri-M Engineering.*

## CHAPTER 1 INTRODUCTION

### 1.1 GENERAL DESCRIPTION

The HESC104+ is a high efficiency, high performance DC-to-DC converter that supplies +3.3V, +5V, +12V & -12V outputs. The HESC104+ also includes a flash based microcontroller that supplies advanced power management, smart battery charger and the PCI-104 bus (also known as the Plus connector on the PC/104+ format). The HESC104+ is designed for low noise embedded computer systems, has a wide input range of 6-40V(>6:1) and is ideal for battery or unregulated input applications. The HESC104+ is specifically designed for vehicular applications and has heavy-duty transient suppressors (9000W on both main and secondary inputs) that clamp the input voltage to safe levels, while maintaining normal power supply operation.

The HESC104+ is a state-of-the-art Mosfet based design that provides outstanding line and load regulation with efficiencies up to 90 percent. Organic Semiconductor Capacitors provide filtering that reduces ripple noises below 20mV. The low noise design makes the HESC104+ ideal for use aboard aircraft or military applications or wherever EMI or RFI must be minimized. The +5VDC and +12VDC outputs are controlled by a constant frequency architecture regulator that provides excellent line and load transient response.

The HESC104+ provides up to four stages of battery charging and can charge Lead-Acid, NiCd, and NiMh batteries and level two and level three SMBus compatible batteries. Charge currents are up to 4A, and battery charging voltages from 9.5 to 19.5V.

The HESC104+ has advanced power management functions that allows timed on/off control of the HESC104+, notification of changes to main power and changes in the battery status. For example, the HESC104+ can be programmed to power off the main outputs in 60 seconds and then turn them on again 12 hours later.

The HESC104+ can be configured to meet almost any power supply and battery charging need for embedded applications, whether that be a simple +5V application, or providing power for back lighted LCD panels, or a full UPS (un-interruptible power supply configuration).

### 1.2 FEATURES

- DC to DC converter for embedded applications.
- "Load Dump" transient suppression on input power supply.
- Operates from 6VDC to 40VDC input.
- PC/104 size and mounting holes.
- PCI-104 bus.
- Host CPU communicates to HESC104+ through built-in UART.
- Standard 16550 compliant serial port provided for general purpose serial communication.
- 3.3V, 5V, 12V, -12V and battery charger outputs.
- Temperature range -40 to 85C.
- Monitors up to eight external temperatures using I2C digital temperature sensors.
- Optocoupled inputs for ignition, and system "shut-down" pushbutton.

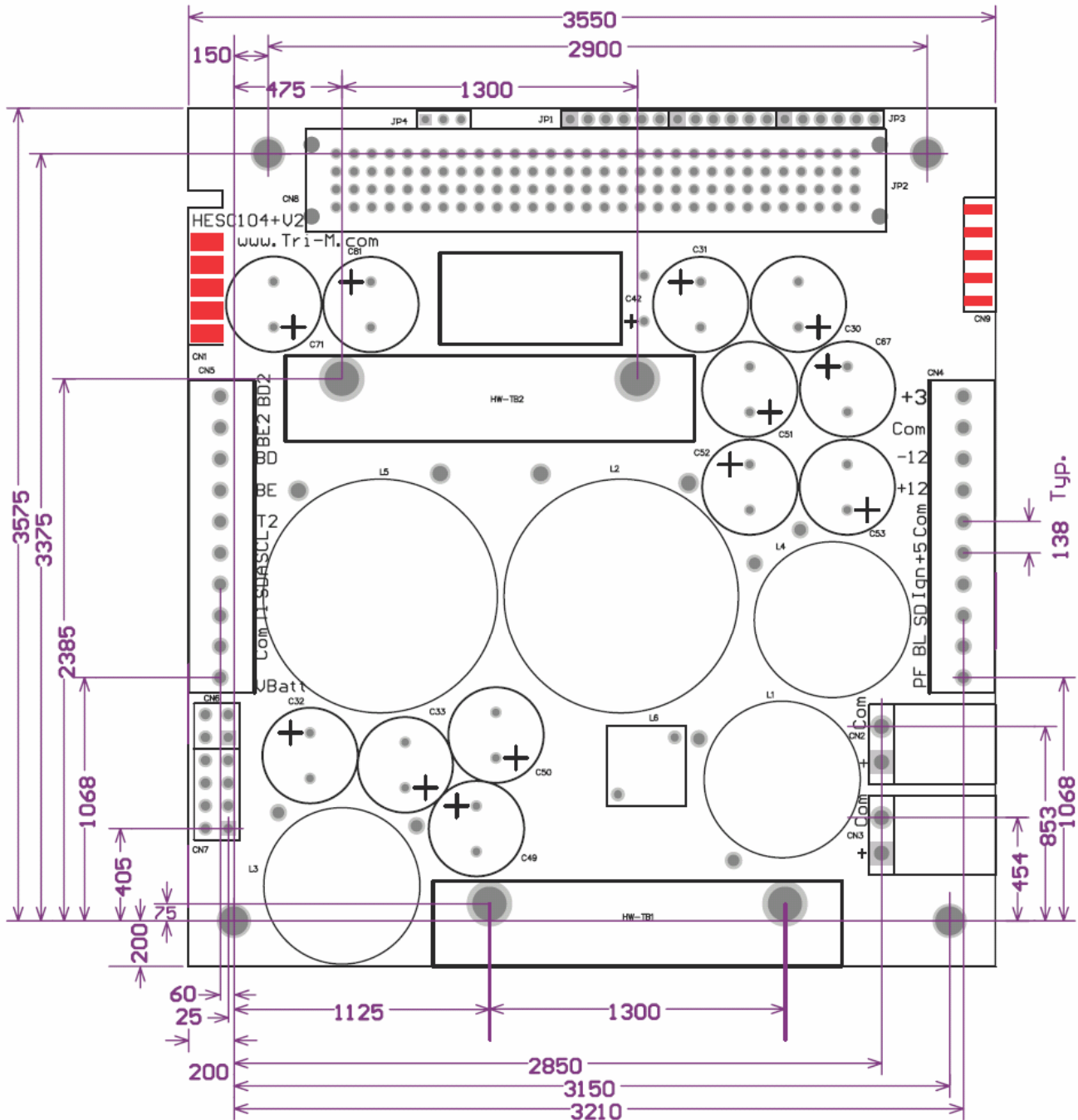

**HESC104+ Mechanical**  
**www.Tri-M.com**

Note: All dimensions in mils (1000mils = 1 inch)

### 1.3 SPECIFICATIONS

<b>Power Supply Specifications</b>	
<b>Model</b>	<b>HESC104+</b>
5V output*	15 A
12V output	3 A
3.3V output	10 A
-12V output	0.5 A
Input Voltage Range	6 to 40V
Load Regulation**	< 60mV
Line Regulation	40mV
Output temp. drift**	< 40mV
Switching Freq.	75kHz
Max. Input Transient	125V for 100msec
Output Ripple**	< 20mV
Conducted Susceptibility**	> 57db
Efficiency	Up to 90%
Temp. Range	-40 to 85C
Size, PC/104 size & mounting holes with PCI-104 bus	3.55"W. x 3.75"L. x 0.6"H.

## CHAPTER 2 CONFIGURATION AND INSTALLATION

### 2.1 Introduction

This chapter describes the configuration and installation of the HESC104+ power supply. In addition, section 2.2 provides a formula to calculate the available +5VDC. Figure 2-1 shows the HESC104+ connectors, jumpers and other options.

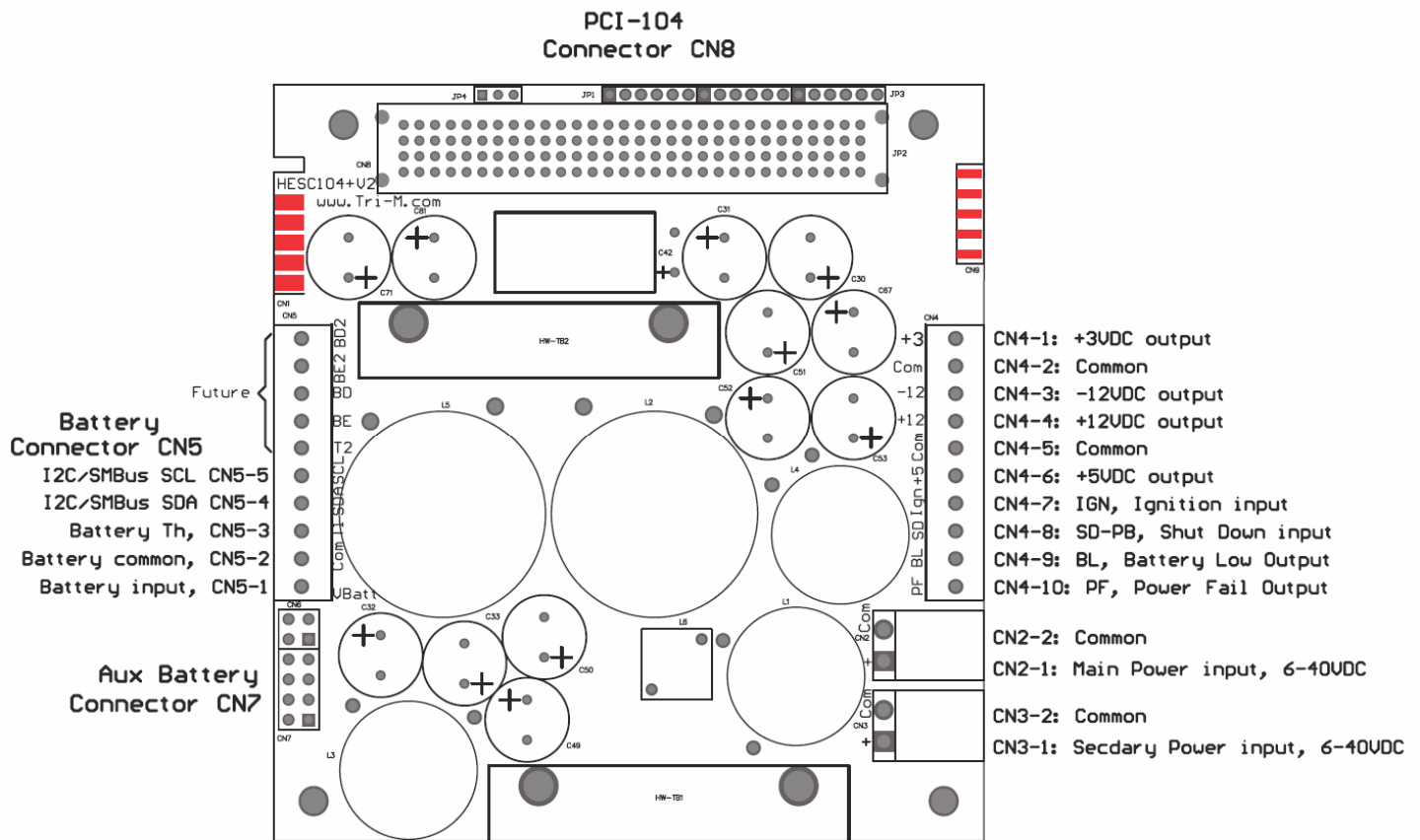

**Figure 2-1: HESC104+ Connectors**

### 2.2 Power Considerations.

The +5V switching regulator is rated at 15A maximum output, however the +5V output supplies power to the +12, and -12VDC regulators. To obtain the usable range of +5V output, “derate” according to the use of +12, and -12VDC. Use the following formulae to calculate the maximum usable output.

Where:

$I[-12]$  = -12VDC current load

$$Usable + 5V output = 15A - \frac{(I[-12] * 2.4 + I[12] * 2.4)}{0.9}$$

$I[12]$  = 12VDC current load

Assuming 90 percent converter efficiency (actual efficiency may vary).

## 2.3 Connector Description and Wiring

The HESC104+ is supplied with removable connectors for easy field installation and service. Connector CN1 is the factory programming port for the on-board microprocessor, and CN2 to CN9 are for power and I/O signals as described in the following sections.

### 2.3.1 Main (CN2) and Secondary (CN3) Input Power Connector

Input power is connected to the HESC104+ by removable connector blocks CN2 and CN3. The power supply accepts DC input voltages in the range of 6VDC to 40VDC. Power may be connector via either CN2 or CN3, or both.

Unregulated vehicle power is connected as follows:

- Terminal 1: "hot" polarity
- Terminal 2: Common (0VDC)

### 2.3.2 Output Power Connector – CN4

Output power is available for use via connector block CN4.

- CN4-1: 3.3VDC output
- CN4-2: Common
- CN4-3: -12VDC output
- CN4-4: +12VDC output
- CN4-5: Common
- CN4-6: +5VDC output
- CN4-7: IGN (Ignition input, ie maintained contact closure) 6-40VDC Input
- CN4-8: SD (Momentary contact closure) 6-40VDC Input
- CN4-9: Position 2, BL (Battery Low signal output) TTL logic level; active low
- CN4-10: Position 3, PF (Power Fail signal output) TTL logic level; active low

Note: All outputs are active low. The active state of the IGN signal is programmable by using SCU utility.

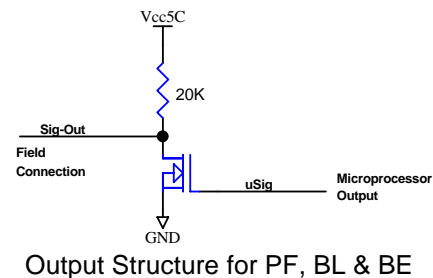
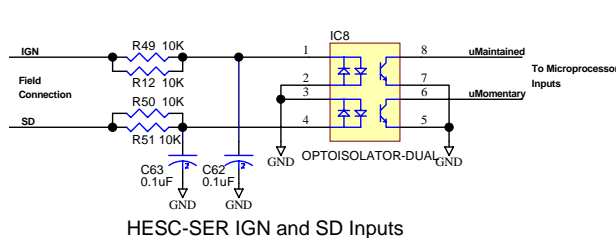

### 2.3.3 Battery Connector – CN5

Batteries are connected via the connector block, CN5. The HESC104+ accepts DC battery voltages in the range 6.5V to 35VDC through the Battery Power Connector.

- CN5-1: Battery Positive.
- CN5-2: Common.
- CN5-3: TH, thermistor/safety input.
- CN5-4: SDA, I2C/SMBus data input/output signal.
- CN5-5: SCL, I2C/SMBus clock input/output signal.
- CN5-6: TH2, second thermistor/safety input.
- CN5-7: BE1: Enable primary battery pack discharging.
- CN5-8: BC1: Enable primary battery pack charging.
- CN5-9: BE2: Enable secondary battery pack discharging.
- CN5-10: BC2: Enables secondary battery pack charging.

### 2.3.4 Aux Battery Connectors – CN6 & CN7

Tri-M Engineering battery packs such as the BAT104-NiCd, BAT104-NiMh, BAT104-SLA25 and BAT104-SLA45 can be directly plugged into the HESC104+ through connector CN7. Connector CN7 is a two row by four-pin header, with the BAT104 battery packs having a mating female connector.

- CN7-1: Battery Positive.
- CN7-2: Common.
- CN7-3: Battery Positive.
- CN7-4: Common.
- CN7-5: SDA, I2C/SMBus data input/output signal.
- CN7-6: SCL, I2C/SMBus clock input/output signal.
- CN7-7: +5VC, +5V for digital temperature sensor and battery enable.
- CN7-8: BE1, Enable primary battery pack discharging.
- CN6-1: BC1: Enable primary battery pack charging.
- CN6-2: BE2: Enable secondary battery pack discharging.
- CN6-3: BC2: Enables secondary battery pack charging.
- CN6-4: Reserved.

### 2.2.5 PCI-104 Bus Connector – CN8

The table below lists the signals used on the PCI-104 bus.

PC/104+ Bus Connector (CN8)				
Pin	A	B	C	D
1	GND	NC	+5V	AD00
2	VI/O	AD02	AD01	+5V
3	AD05	GND	AD04	AD03
4	C/BE0	AD07	GND	AD06
5	GND	AD09	AD08	GND
6	AD11	VI/O	AD10	PMEX
7	AD14	AD13	GND	AD12
8	+3.3V	CBE1	AD15	+3.3V
9	SERR	GND	SB0	PAR
10	GND	PERR	+3.3V	SDONE
11	STOP	+3.3V	LOCK	GND
12	+3.3V	TRDY	GND	DEVSEL
13	FRAME	GND	IRDY	+3.3V
14	GND	AD16	+3.3V	C/BE2
15	AD18	+3.3V	AD17	GND
16	AD21	AD20	GND	AD19
17	+3.3V	AD23	AD22	+3.3V
18	N/A	GND	N/A	IDSEL2
19	AD24	C/BE3	VI/O	IDSEL3
20	GND	AD26	AD25	GND
21	AD29	+5V	AD28	AD27
22	+5V	AD30	GND	AD31
23	N/A	GND	N/A	VI/O
24	GND	REQ2	+5V	N/A
25	N/A	VI/O	GNT2	GND
26	+5V	N/A	GND	N/A
27	CLK_PCI_2	+5V	CLK_PCI_3	GND
28	GND	INTD	+5V	RST
29	+12V	N/A	N/A	INTB
30	-12V	NC	NC	GND

### 2.3.6 Serial Port Connector – CN9

The Aux serial port provided on connector CN9 has two modes of operation, “Normal” and “Redirect”. Selection of the mode is controlled by the signal level on CN9 pin-10. When no connection is made to CN9 pin-10 the serial port is in normal mode. When CN9 pin-10 is pulled to CN9 pin-9 (GND), the serial port is in redirect mode.

#### Normal mode operation (CN9 pin-10 floating):

A 16550 equivalent serial port is available for use by the Host CPU over CN8 (PCI bus). The signals on the serial port CN9 connect through the on-board UART providing a full complement of input and output handshaking lines. These signals are at standard RS232C levels.

**Table 2-1: Aux Serial Port (CN9) in Normal Mode (CN9 pin-10 floating)**

CN9	DB-9 Pin	Signal	Function	In/Out	CN9	DB-9 Pin	Signal	Function	In/Out
1	1	DCD1	Serial 1 Data Carrier Detect	IN	2	6	DSR1	Serial 1 Data Set Ready	IN
3	2	RXD1	Serial 1 Receive Data	IN	4	7	RTS1	Serial 1 Request To Send	OUT
5	3	TXD1	Serial 1 Transmit Data	OUT	6	8	CTS1	Serial 1 Clear To Send	IN
7	4	DTR1	Serial 1 Data Terminal Ready	OUT	8	9	RI1	Serial 1 Ring Indicator	IN
9	5	GND	Signal Ground	GND	10	N/A	ModeS	Mode select signal	IN

\* Equivalent signals if wired to a DB-9 connector

#### Redirect mode (CN9 pin-10 connected to CN9 pin-5):

The TX (CN9 pin-5) and RX (CN9 pin-3) signals are redirected to the microprocessor on-board the HESC104+. While in redirect mode, the Host CPU residing on the PCI bus will not be able to communicate via the Uart to the HESC104+ via the built-in Uart. However, the handshake lines (PF, BL & SD) of the built-in interface to the Uart remain functional, allowing the Host CPU to monitor if there is a pending shutdown or low battery condition and the Host CPU can request the HESC104+ turn off the main outputs through the SD line.

While in Redirect mode a remote CPU (such as a lap top) can monitor and interact with the HESC104+ while it is embedded into an application.

The full HESC-UPS18 firmware command set is supported over the Redirect serial port. Communications settings are 9600 baud, no parity and one stop bit.

## 2.4 Jumper Selection

This section describes the function of each jumper, the location of it, the default setting, and how to change it.

### 2.4.1 LED Jumper Enable/Disable

There are no jumpers on the HESC104+ to disable the LEDs. If the LEDs must be disabled then the current limiting resistor can be easily removed. The HESC104+ can be factory ordered in this configuration for OEM quantities. Please contact Tri-M sales for details.

### 2.3.2 PCI ID Select (JP1)

The PC104+ allows up to 4 PCI devices, each device has to be identified with a different ID number. The jumper JP1 selects a PCI Device ID for the HESC104+.

PCI DEVICE ID	JP1
PIDSEL0	1-2
PIDSEL1	2-3
PIDSEL2	4-5
PIDSEL3	5-6

### 2.3.3 PCI Clock Select (JP2)

To reduce the load on the PCI clock the PC104+ bus provides 4 PCI clock lines, it's normally intend to have one clock line by device. The jumper JP2 is used to attribute a PCI clock for the HESC104+.

PCI CLOCK	JP2
CLKPCI0	1-2
CLKPCI1	2-3
CLKPCI2	4-5
CLKPCI3	5-6

### 2.3.4 PCI Interrupt Select (JP3)

The jumper JP3 is used to select a PCI interrupt line for the HESC104+. In opposition to the device ID, this line can be shared with another PCI device.

PCI INTERRUPT	JP3
INTA	1-2
INTB	2-3
INTC	4-5
INTD	5-6

### 2.4.2 PCI I/O voltage Select (JP4)

The PC104+ bus allows devices i/o level to be 5V or 3.3V, the jumper JP4 select the voltage of the io lines. **The selection is made for the PC104+ bus and will be applied to all devices on the stack.**

PCI I/O VOLTAGE	JP4
5V	1-2
3.3V	2-3

## CHAPTER 3: Power Management Features

### 3.1 Introduction

The HESC104+ has extensive power management feature when it is loaded with the HESC-UPS18 firmware including:

- Debounce timers on the main input.
- Debounce timers on the Shutdown input (SD).
- Separate start up and shutdown timers for the main input, SD input, PS (momentary contact input), and the PC/104 Host interface.
- Shut down timer for the low battery voltage or capacity.

Please refer to the HESC-UPS18 manual for details on the power management functions of the HESC-UPS18 firmware.

### 3.2 Input and output active polarity

The HESC monitors the main input, maintained contact input, momentary contact input, battery input, SMBus, and is capable of alerting the host through the PF, and BL output or the Host CPU can poll the HESC104+ through the built-in UART over the PCI-104 bus..

The SD input can be configured to be active high or active low. The polarity is set by changing bit 3 at location 80 in the HESC104+ EEPROM. Tri-M Engineering supplies a free Microsoft Windows based utility called the Smart Charger Utility (SCU.exe) that simplifies making changes to the HESC104+ configuration.

BL is driven low when the battery voltage is below the Minimum Battery Operating Voltage EEPROM setting. Figure 3-2 shows this setting under the SCU "OTHER" EEPROM setpoints page. Please note the unit of 9400 is in millivolts.

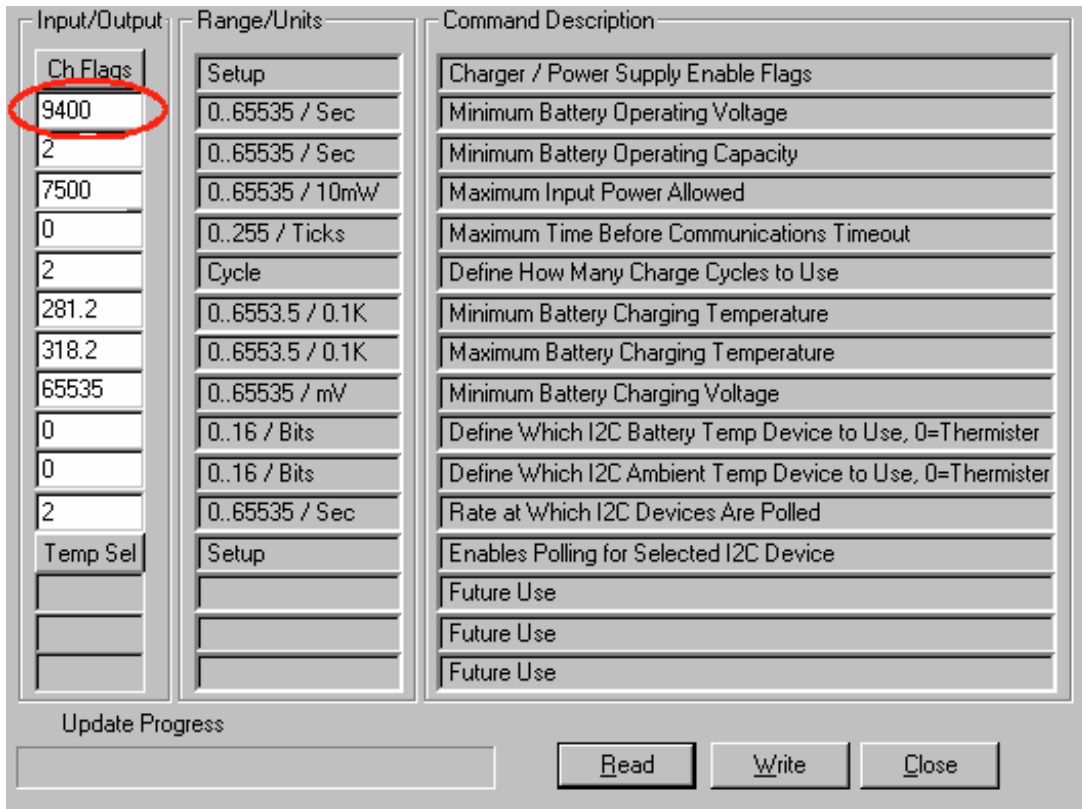

Figure 3-2

PF is driven active low after the main input power is removed and the "debounce" interval is completed or whenever there is a pending shutdown of the main outputs.

BL and PF can be used to signal the host CPU to prepare for shutdown. It is critical that operating systems such as Linux and Windows are shutdown gracefully otherwise corruption of the OS and the file system may result.

## CHAPTER 4: External Battery Design

### Battery Isolation

The HESC series products allow an external backup battery to be connected. For applications where long periods of power interruption may occur, a Mosfet isolation circuit should be used to prevent deep cycling the batteries. Below is a circuit complete with typical component values.

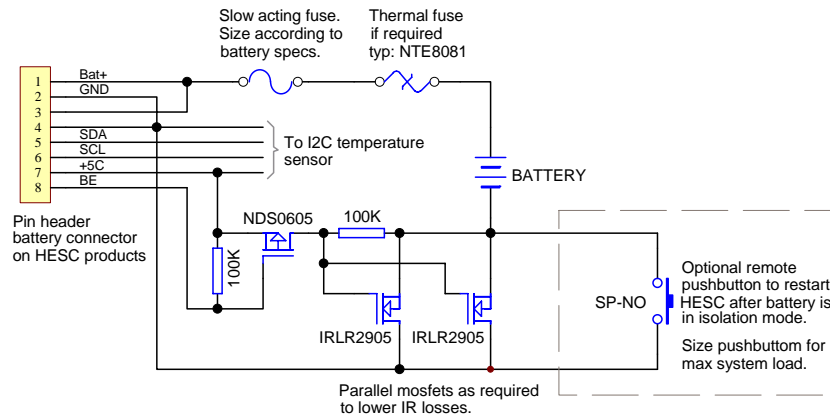

Figure 4-1: Battery Mosfet Isolation Circuit

### Digital Sensor Interface

The HESC series support I<sup>2</sup>C digital temperatures of Microchip (TCN75) and National (LM75CIM). These I<sup>2</sup>C are “two wire” devices and require connection of a bi-directional data line (SDA) and a bidirectional clock line (SCL). In addition, 5V power and Gnd are required. Both SDA and SCL along with 5V and Gnd are available through the eight-pin battery header connector (see Figure A1) on HESC products. SDA and SCL are also available on the five-position screw terminal block (see section 2.3.3) on the HESC104+.

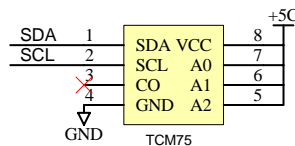

Figure 4-2: Digital Temperature Sensor