

revision 0.4

Solid State Drive

*MSD-SATA3035*

## Product Specification

---

Jun. 3<sup>rd</sup>, 2008



Revision History				
No.	Date	History	Reference	Remark
0.1	Nov. 9. 2007	Initial issue		Preliminary
0.2	Jan. 21. 2008	Add Environment Specifications	5.1 5.4	Preliminary
0.3	Apr. 11. 2008	Change Physical Dimensions	2.1	Preliminary
0.4	Jun. 3. 2008	Add Environment Specifications	5.2 5.3	Preliminary

## Table of Contents

<b>1.</b>	<b>General Description .....</b>	<b>4</b>
1.1	Overview .....	4
1.2	Feature .....	4
1.3	Block Diagram .....	5
<b>2.</b>	<b>Physical Specifications .....</b>	<b>6</b>
2.1	Physical Dimensions .....	6
<b>3.</b>	<b>Product Specifications .....</b>	<b>7</b>
3.1	Interface .....	7
3.2	Capacity .....	7
3.3	Performance .....	8
3.3.1	Transfer rate and IOPS .....	8
3.3.2	Access time .....	8
3.4	Reliability Characteristics .....	9
3.4.1	Wear-leveling .....	9
3.4.2	Endurance .....	9
3.4.3	ECC .....	9
3.4.4	Bad block management algorithm .....	9
3.4.5	MTBF .....	9
3.4.6	Data retention .....	9
<b>4.</b>	<b>Electric Specifications .....</b>	<b>10</b>
4.1	Pin Description .....	10
4.1.1	Pin location .....	10
4.1.2	Signal connector pin assignment .....	10
4.1.3	Power connector pin assignment .....	11
4.2	Supply Voltage .....	12
4.3	Power Consumption .....	12
<b>5.</b>	<b>Environmental Specifications .....</b>	<b>13</b>
5.1	Temperature .....	13
5.2	Shock .....	13
5.3	Vibration .....	14
5.4	Humidity .....	14
5.5	Altitude .....	14
<b>6.</b>	<b>Command Description .....</b>	<b>15</b>

---

6.1	Supporting ATA Command Set.....	15
6.2	SMART Feature Set.....	16
6.2.1	Sub command set.....	16
6.2.2	SMART data structure.....	17
6.2.3	Total erase count.....	19
6.2.3.1	Total erase count current value.....	19
6.2.3.2	Total erase count worst value.....	19
6.2.3.3	Total erase count raw value.....	19
6.3	Set Features.....	20
6.3.1	Set features register value.....	20
<b>7.</b>	<b>Ordering Information.....</b>	<b>21</b>
<b>8.</b>	<b>Contacts .....</b>	<b>22</b>

---

# 1. General Description

---

## 1.1 Overview

Mtron SSD is a high performance storage device designed to solve the bottleneck of computing system by traditional hard disk drives. Mtron SSD can be drop-in replaced with the hard disk drives without any additional software installation. Customer can benefit instantly from Mtron SSD's high random access performance and solve the legacy problem of access bottleneck by traditional hard disk drives.

Mtron SSD purely consists of semiconductor devices and NAND flash memories, which give rugged features against shock and vibration with an increased MTBF. Furthermore, Mtron SSD has highly elaborated and advanced flash memory management algorithm to guarantee high data reliability.

With Mtron SSD's superior performance, reliability and durability, Mtron SSD increases overall performance and values of system in mobile computing and enterprise system solutions.

---

## 1.2 Feature

- > Performance
  - Maximum sustained read: 100MB/s
  - Maximum sustained write: 80MB/s
  - Maximum IOPS: 79,000 (sequential read by 512B unit)
- > Form factor: 146.0mm x 101.6mm x 14.8mm
- > Memory type: SLC NAND flash memory
- > Interface standard: SATA revision 1.0a
- > Transfer mode: PIO mode (0~4), DMA mode (0~2), UDMA mode (0~6)
- > Storage capacity: 16GB, 32GB, 64GB, 128GB
- > Input voltage: 5VCC ( $\pm 5\%$ )
- > Flash management algorithm: static and dynamic wear-leveling, bad block management algorithm
- > ECC (Error Correction Code): BCH 7 bits ECC
- > Write endurance: >140 years @ 50GB write/day at 32GB SSD
- > Read endurance: unlimited
- > Data retention: 10 years

## 1.3 Block Diagram

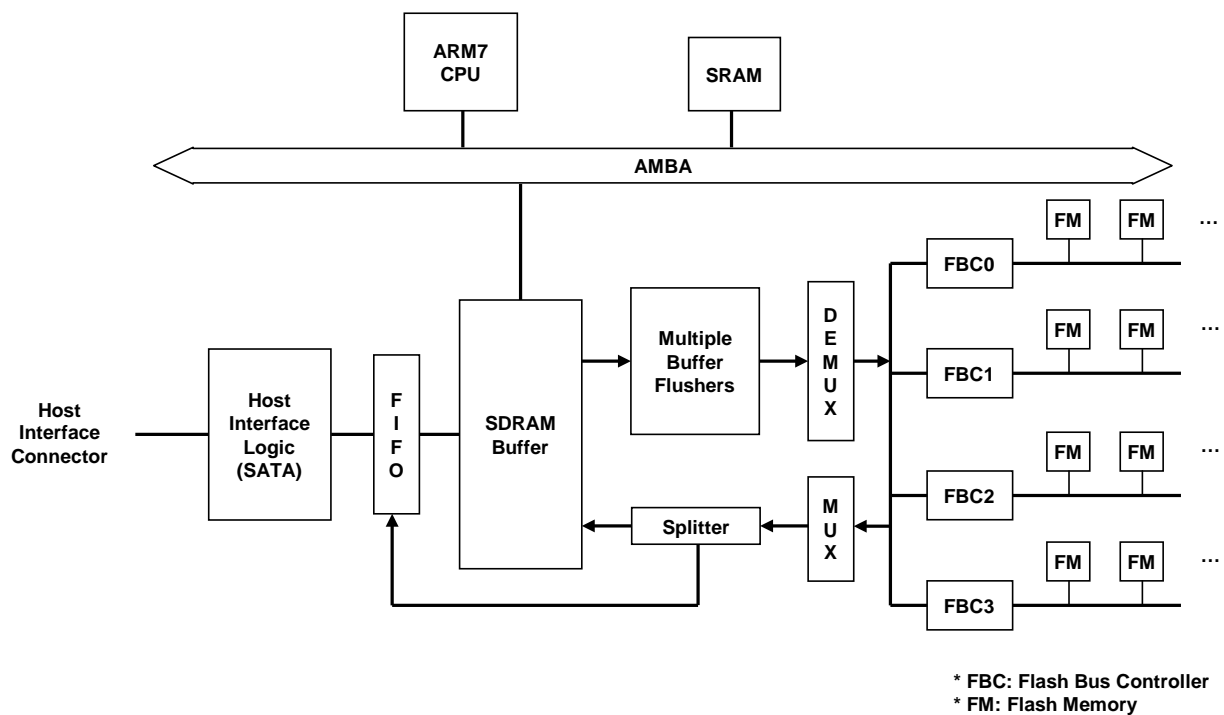

Figure 1 Block Diagram

## 2. Physical Specifications

### 2.1 Physical Dimensions

**Table 1 Physical Dimensions and Weight**

Parameter	Value	Unit
Height	14.8 ±0.25	mm
Width	101.6 ±0.20	mm
Length	146.0 ±0.25	mm
Maximum Weight	206	g

**Note:**

1. Case material: Aluminum
2. Test drive: MSD-SATA3035-032

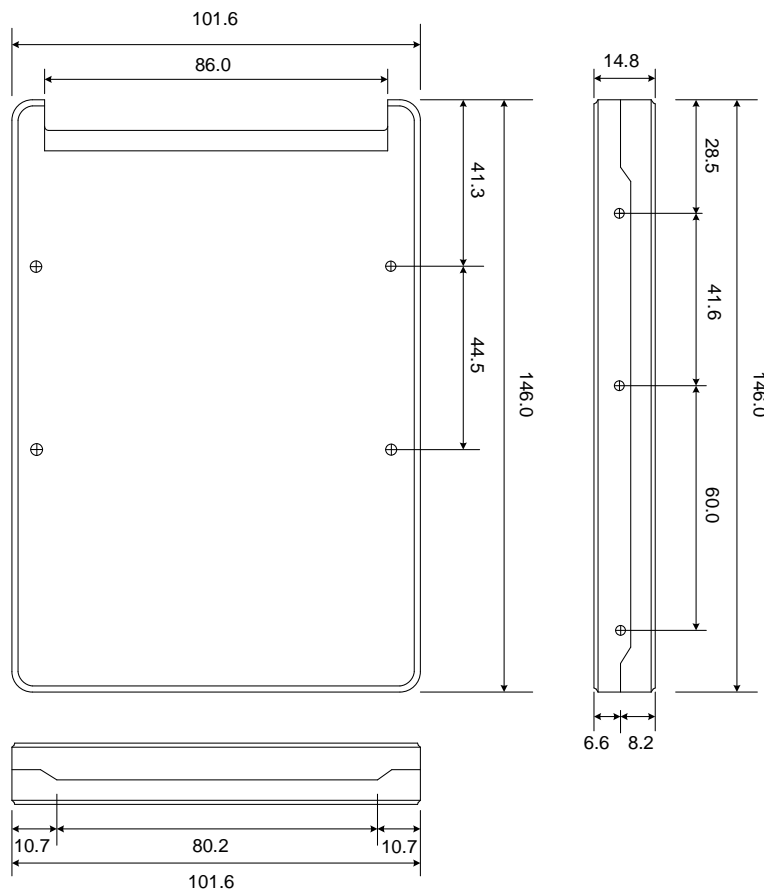

(Unit: mm)

**Figure 2 Physical Dimensions**

## 3. Product Specifications

### 3.1 Interface

- > The interface of MSD-SATA3035 complies with the standard serial ATA revision 1.0a.
- > Transfer modes:
  - PIO mode 0, 1, 2, 3, 4
  - DMA mode 0, 1, 2
  - UDMA mode 0, 1, 2, 3, 4, 5, 6

### 3.2 Capacity

**Table 2 Capacity Specifications**

Capacity	16GB	32GB	64GB	128G
Total Byte	16,001,269,760	32,002,539,520	64,000,884,736	128,001,769,472
Cylinders	16383*	16383*	16383*	16383*
Heads	16	16	16	16
Sectors	63	63	63	63
Max. LBA	31,252,480	62,504,960	125,001,728	250,003,456

**Note:**

1. 16383: Cylinders, Heads, Sectors are not applicable for the capacities. Only LBA addressing applies.

### 3.3 Performance

#### 3.3.1 Transfer rate and IOPS

**Table 3 Maximum Data Transfer Rate**

Data Transfer	Maximum Read	Maximum Write	Unit
Sustained Rate	100	80	MB/s

**Note:**

1. Test PC: AMD Athlon™ 4800+ Dual Core (2.4GHz) 1GB RAM, NVIDIA nForce 570 Ultra MCP (UDMA133), Windows XP SP2
2. Benchmarking program: ATTO Disk benchmark 2.02 (Transfer unit size = 128KB)
3. Test drive: MSD-SATA3035-032

**Table 4 IO Performance Values**

Access Type	IOPS operation unit size	
	512B	4KB
Sequential Read	79,000	11,100
Sequential Write	41,700	16,600
Random Read	16,500	11,200
Random Write	120	120

**Note:**

1. Test PC: AMD Athlon™ 4800+ Dual Core (2.4GHz) 1GB RAM, NVIDIA nForce 570 Ultra MCP (UDMA133), Windows XP SP2
2. Benchmarking program: IOMeter 2006.07.27 (Maximum disk size = 2,000,000 sectors (1GB), Outstanding I/O per target = 8, Duration = 1min)
3. Test drive: MSD-SATA3035-032

#### 3.3.2 Access time

Random access time: 0.1 msec

**Note:**

1. Test PC: AMD Athlon™ 4800+ Dual Core (2.4GHz) 1GB RAM, NVIDIA nForce 570 Ultra MCP (UDMA133), Windows XP SP2
2. Benchmarking Program: HDTach 3.0.1
3. Test drive: MSD-SATA3035-032

## 3.4 Reliability Characteristics

### 3.4.1 Wear-leveling

Mtron SSD supports both static and dynamic wear-leveling. These two algorithms guarantee the use of all flash memory at the same level of write/erase cycles to improve lifetime limitation of NAND based storage.

### 3.4.2 Endurance

**Table 5 Endurance**

<b>Write</b>	At 32GB capacity: <b>&gt;140 years @ 50GB write/day</b>
<b>Read</b>	Unlimited

**Note:**

1. The above calculation is based on the guaranteed 100,000 program and erase cycles of type of SLC type flash memory from vendors and the assumption that the write is performed in sequential manner.

### 3.4.3 ECC

BCH ECC (Error Correction Code) corrects random 7 bits error in 512B data.

### 3.4.4 Bad block management algorithm

This algorithm replaces bad blocks with new ones from available spares on media error conditions.

### 3.4.5 MTBF

MTBF (Mean Time between Failures): 1,000,000 hours

**Note:**

1. Prediction method: Telcordia TR-332

### 3.4.6 Data retention

Data retention at 25°C: >10 years

## 4. Electric Specifications

### 4.1 Pin Description

#### 4.1.1 Pin location

The following diagram identifies the pin location of MSD-SATA3035.

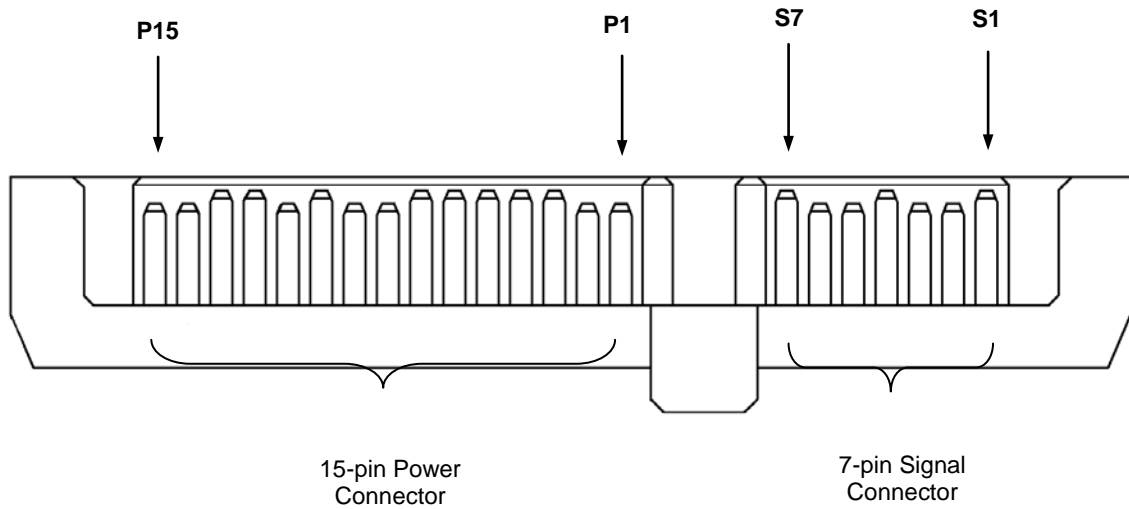

**Figure 3 Pin Location**

#### 4.1.2 Signal connector pin assignment

**Table 6 Signal Connector Pin Assignment**

Pin Number	Signal Name	Description
S1	GND	2nd mate
S2	A+	Differential signal pair A From physical layer electronics
S3	A-	
S4	GND	2nd mate
S5	B-	Differential signal pair A From physical layer electronics
S6	B+	
S7	GND	2nd mate

## 4.1.3 Power connector pin assignment

**Table 7 Power Connector Pin Assignment**

Pin Number	Signal Name	Description
P1	V33	3.3V power
P2	V33	3.3V power
P3	V33	3.3V power, pre-charge, 2nd mate
P4	GND	1st mate
P5	GND	2nd mate
P6	GND	2nd mate
P7	V5	5V power, pre-charge, 2nd mate
P8	V5	5V power
P9	V5	5V power
P10	GND	2nd mate
P11	Reserved	1. Corresponding pin in backplane is reserved 2. Corresponding pin in power cable shall be always grounded
P12	GND	1st mate
P13	V12	12V power, pre-charge, 2nd mate
P14	V12	12V power
P15	V12	12V power

## 4.2 Supply Voltage

**Table 8 Supply Voltage**

Parameter	Specifications	Unit
Main Supply Voltage	5.0 ± 5%	VDC
Maximum Ripple	100mV (peak to peak), 0-30MHz	-
Supply Rise Time	7 to 100	msec

## 4.3 Power Consumption

**Table 9 Power Consumption**

Operation Mode	Value	Unit
Idle	0.50	W
Sustained Read	1.66	W
Random Read	1.66	W
Sustained Write	2.43	W
Random Write	1.70	W

**Note:**

1. Measurement device: Agilent Technologies N6705A
2. Benchmarking program: IOMeter 2006.07.27 (Maximum disk size = 2,000,000 sectors (1GB), Outstanding I/O per target = 8, Duration = 1min, Transfer unit size = 256KB)
3. Supply voltage: 5V±5%
4. Test drive: MSD-SATA3035-032

---

## 5. Environmental Specifications

---

### 5.1 Temperature

**Table 10 Temperature**

Parameter	Specifications	Unit
Operating	0 to 70	°C
Non-Operating	-40 to 85	°C

**Note:**

1. Test duration: 95h 20min
2. Test drive: MSD-SATA3035-032

---

### 5.2 Shock

**Table 11 Shock**

Parameter	Acceleration Force	Unit
Operating	TBD	-
Non-Operating	2000	G

**Note:**

1. Test pulse shape: half sine
2. Test duration: 0.3msec
3. Test drive: MSD-SATA3035-032

---

## 5.3 Vibration

**Table 12 Vibration**

Parameter	Specifications	Unit
Operating	TBD	-
Non-Operating	20G, 40-2000Hz	-

**Note:**

1. Test duration: 2h for each X,Y,Z axis 20min/sweep
2. Test drive: MSD-SATA3035-032

---

## 5.4 Humidity

**Table 13 Operating Humidity**

Parameter	Specifications	Unit
Operating	5 to 95	%

**Note:**

1. Test duration: 95h 20min
2. Test drive: MSD-SATA3035-032

---

## 5.5 Altitude

TBD

## 6. Command Description

### 6.1 Supporting ATA Command Set

**Table 14 Supporting ATA Commands**

Command Name	Command Code
Recalibrate	10h
Read Sector(s)	20h
Write Sector(s)	30h
Read Verify Sector(s)	40h
Execute Device Diagnostic	90h
Initialize Device Parameters	91h
Download Microcode	92h
SMART	B0h
Read Multiple	C4h
Write Multiple	C5h
Set Multiple Mode	C6h
Read DMA	C8h
Write DMA	CAh
Standby Immediate	E0h
Idle Immediate	E1h
Standby	E2h
Idle	E3h
Check Power Mode	E5h

Command Name	Command Code
Sleep	E6h
Flush Cache	E7h
Identify Device	ECh
Set Features	EFh
Read Native Max Address	F8h
Set Max Address	F9h

**Note:**

1. Firmware version: 0.18 R1

---

## 6.2 SMART Feature Set

### 6.2.1 Sub command set

**Table 15 SMART Sub Command Set**

SMART	
Read Data	D0h
Read Attribute Thresholds	D1h
Enable/Disable Autosave	D2h
Enable Operations	D8h
Disable Operations	D9h
Return Status	DAh

## 6.2.2 SMART data structure

**Table 16 SMART Data Structure (READ DATA (D0h))**

Byte	F/V	Description
0~1	X	Structure version (0x0001)
2	X	Attribute ID 0xBB: Total Erase Count *1
3~4	X	Flags (0x02) 15-6 Reserved 5-2 Vendor-specific 1 1=The value of this attribute is updated during both normal operation and offline activities 0 0=The usage of age of the device has exceeded its intended design life period
5	V	Total erase count current value *2
6	V	Total erase count worst value *3
7~12	V	Total erase count raw value *4
13~361	X	Vendor specific
362	V	Off-line data collection status
363	X	Self-test execution status byte
364~365	V	Total time in seconds to complete off-line data collection activity
366	X	Vendor specific
367	F	Off-line data collection capability
368~369	F	SMART capability (0x0002) 15-2 Reserved 1 1= Device supports the SMART ENABLE/DISABLE ATTRIBUTE AUTOSAVE command 0 1= Device saves SMART data prior to going into a power saving mode (Idle, Standby, or Sleep) or immediately upon return to Active or Idle mode from a Standby mode
370	F	Error logging capability (0x00) 7-1 Reserved 0 1=Device error logging supported
371	X	Vendor specific
372	F	Short self-test routine recommended polling time (in minutes)

Byte	F/V	Description
373	F	Extended self-test routine recommended polling time (in minutes)
374~385	R	Reserved
386~510	X	Vendor specific
511	V	Data structure checksum

**Key :**

F=the content of the byte is fixed and does not change.

V=the content of the byte is variable and may change depending on the state of the device or the commands executed by the device.

X=the content of the byte is vendor specific and may be fixed or variable.

R=the content of the byte is reserved and shall be zero.

**Note:**

1. Refer to 6.2.3
2. Refer to 6.2.3.1
3. Refer to 6.2.3.2
4. Refer to 6.2.3.3

**Table 17 SMART Data Structure (READ Threshold (D1h))**

Byte	F/V	Description
0~1	X	Structure version (0x0001)
2	X	Attribute ID 0xBB: Total Erase Count
3	X	Total erase count Threshold (0x00)
4~13	R	Reserved
14~361	R	2 <sup>nd</sup> ~ 30 <sup>th</sup> Attribute Threshold (reserved)
362~379	R	Reserved
380~510	X	Vendor specific
511	V	Data structure checksum

**Key :**

F=the content of the byte is fixed and does not change.

V=the content of the byte is variable and may change depending on the state of the device or the commands executed by the device.

X=the content of the byte is vendor specific and may be fixed or variable.

R=the content of the byte is reserved and shall be zero.

### 6.2.3 Total erase count

Total Erase Count means the summation of erase counts of all blocks in SSD.

In general, the maximum value of 32GB SSD's Total Erase Count is 3200M and if the Total Erase Count exceeds the value, it says that the SSD is completely wore out.

Maximum Total Erase Count differs from vendors of NAND FLASH Chips and the capacity of SSD.

#### 6.2.3.1 Total erase count current value

This value becomes 100 when Total Erase Count is equal to 0 and becomes 0 when Total Erase Count is equal to the maximum value.

If the value is equal to 0, it means that the SSD is completely wore out.

#### 6.2.3.2 Total erase count worst value

This value becomes 100 when Total Erase Count is equal to 0 and becomes 0 when Total Erase Count is equal to 90% of maximum value.

Users should be warned when this value becomes 0.

#### 6.2.3.3 Total erase count raw value

This value means the summation of erase counts of all blocks in SSD.

---

## 6.3 Set Features

### 6.3.1 Set features register value

**Table 18 Set Features Register Value**

Set Features	
Enable Write Cache	02h
Set Transfer Mode	03h
Disable Read Look-ahead Feature	55h
Disable Reverting to Power-on Defaults	66h
Enable Read Look-ahead Feature	AAh
Enable Reverting to Power-on Defaults	CCh
Disable Write Cache	82h

## 7. Ordering Information

**Table 19** Information

MSD-IFIF30FF-CCC		
MSD	Product Code	MSD: Mtron SSD MOBI
IFIF	Interface	SATA: SATA revision 1.0a
30	Appliance	Mobile Platform (SLC)
FF	Form Factor	35: 3.5-inch
CCC	Unformatted Capacity (GB)	016: 16GB 032: 32GB 064: 64GB 128: 128GB

## 8. Contacts

**MTRON STORAGE TECHNOLOGY CO., LTD.**

Suite 807, SuntechCity II, Sangdaewon-Dong, Jungwon-Gu,  
Seongnam-City, Gyeonggi-Do, Korea (462-806)

Tel: +82-31- 737-4820

FAX: +82-31-737-4829

Homepage: [www.mtron.net](http://www.mtron.net)

Email: Product & Partnership - [marketing@mtron.net](mailto:marketing@mtron.net)

Sales & Distribution - [sales@mtron.net](mailto:sales@mtron.net)

INFORMATION IN THIS PRODUCT SPECIFICATION IS SUBJECT TO CHANGE AT ANYTIME WITHOUT PRIOR NOTICE.

ALL PRODUCT SPECIFICATIONS ARE PROVIDED FOR REFERENCE PURPOSES ONLY.

NO PART OF THIS DOCUMENT MAY BE REPRODUCED, TRANSMITTED, TRANSCRIBED, STORED IN A RETRIEVABLE MANNER OR TRANSLATED INTO ANY LANGUAGE OR COMPUTER LANGUAGE, IN ANY FORM OR BY ANY MEANS, ELECTRONIC, MECHANICAL, MAGNETIC, OPTICAL, CHEMICAL, MANUAL OR OTHERWISE, WITHOUT PRIOR WRITTEN CONSENT OF MTRON.

NOTHING IN THIS DOCUMENT SHALL BE CONSTRUED AS GRANTING ANY LICENSE, EXPRESS OR IMPLIED, BY ESTOPPEL OR OTHERWISE, TO ANY INTELLECTUAL PROPERTY RIGHTS IN MTRON PRODUCTS OR TECHNOLOGY.

ALL INFORMATION IN THIS DOCUMENT IS PROVIDED ON AS "AS IS" AND WITHOUT GUARANTEE OR WARRANTY OF ANY KIND.

1. *For updates or additional information about Mtron products, contact your nearest Mtron office.*
2. *Mtron products are not warranted to operate without failure. Accordingly, Mtron products are not intended for use in life support, critical care, medical, safety equipment, or similar applications where product failure could result in loss of life or personal or physical harm, or any military or defense application, or any governmental procurement to which special terms or provisions may apply.*
3. *Mtron products should only be incorporated in systems designed with appropriate and sufficient redundancy or backup features.*
4. *Performance and the power consumption of the Mtron products have various specifications under the conditions of the capacity and the type of flash memory being used.*

Contact your local Mtron sales office or distributor, or visit our website at [www.mtron.net](http://www.mtron.net) to obtain the latest specifications before placing your order.

*Copyright © 2007 by MTRON STORAGE TECHNOLOGY CO., LTD. All rights reserved.*

*Printed in R.O.K*